

# Agenda

Guildford  
Local Committee

**We welcome you to  
Guildford Local Committee**  
Your Councillors, Your Community  
and the Issues that Matter to You

## Discussion

**Early Help - Children, Young  
People and Families**

**Unlocking Transportation  
(Guildford)**

**Highways Schemes - Budget**



## Venue

**Location:** Council Chamber,  
Guildford Borough  
Council, Millmead, GU2  
4BB

**Date:** Wednesday, 21 March  
2018

**Time:** 7.00 pm



SURREY

# Get involved

## You can get involved in the following ways

### ***Ask a question***

If there is something you wish know about how your council works or what it is doing in your area, you can ask the local committee a question about it. Most local committees provide an opportunity to raise questions, informally, up to 30 minutes before the meeting officially starts. If an answer cannot be given at the meeting, they will make arrangements for you to receive an answer either before or at the next formal meeting.

### ***Write a question***

You can also put your question to the local committee in writing. The committee officer must receive it a minimum of 4 working days in advance of the meeting.

When you arrive at the meeting let the committee officer (detailed below) know that you are there for the answer to your question. The committee chairman will decide exactly when your answer will be given and may invite you to ask a further question, if needed, at an appropriate time in the meeting.

### ***Sign a petition***

If you live, work or study in Surrey and have a local issue of concern, you can petition the local committee and ask it to consider taking action on your behalf. Petitions should have at least 30 signatures and should be submitted to the committee officer 2 weeks before the meeting. You will be asked if you wish to outline your key concerns to the committee and will be given 3 minutes to address the meeting. Your petition may either be discussed at the meeting or alternatively, at the following meeting.



**Thank you for coming to the Local Committee meeting**

Your Partnership officer is here to help. If you would like to talk about something in today's meeting or have a local initiative or concern please contact them through the channels below.

*Email:* [joanna.long@surreycc.gov.uk](mailto:joanna.long@surreycc.gov.uk)

*Tel:* 01483 517336

*Website:* <http://www.surreycc.gov.uk/guildford>



*Follow @GuildfordLC on Twitter*

---

## **Surrey County Council Appointed Members**

Mr Keith Taylor, Shere (Chairman)  
Mr Mark Brett-Warburton, Guildford South East  
Mr Graham Ellwood, Guildford East  
Mrs Julie Iles, Horsleys  
Mr Matt Furniss, Shalford  
Mrs Angela Goodwin, Guildford North  
Mr David Goodwin, Guildford South West  
Mrs Marsha Moseley, Ash  
Mrs Fiona White, Guildford West  
Mr Keith Witham, Worplesdon

## **Borough Council Appointed Members**

Borough Councillor Paul Spooner, Ash South & Tongham (Vice-Chairman)  
Borough Councillor David Bilbe, Normandy  
Borough Councillor Nils Christiansen, Holy Trinity  
Borough Councillor Nigel Kearse, Ash South and Tongham  
Borough Councillor Julia McShane, Westborough  
Borough Councillor Tony Phillips, Onslow  
Borough Councillor Mike Piper, Burpham  
Borough Councillor David Reeve, Clandon & Horsley  
Borough Councillor Matthew Sarti, Clandon & Horsley  
Borough Councillor David Wright, Tillingbourne

Chief Executive  
**Joanna Killian**

If you would like a copy of this agenda or the attached papers in another format, e.g. large print, Braille, or another language please either call Joanna Long on 01483 517336 or write to the Community Partnerships Team at Surrey County Council, Old Millmead House, Millmead, Guildford, GU2 4BB or [joanna.long@surreycc.gov.uk](mailto:joanna.long@surreycc.gov.uk)

**This is a meeting in public. If you would like to attend and you have any special requirements, please contact us using the above contact details.**

#### MOBILE TECHNOLOGY AND FILMING – ACCEPTABLE USE

Those attending for the purpose of reporting on the meeting may use social media or mobile devices in silent mode to send electronic messages about the progress of the public parts of the meeting.

Anyone is permitted to film, record or take photographs at council meetings. Please liaise with the council officer listed in the agenda prior to the start of the meeting so that those attending the meeting can be made aware of any filming taking place.

Use of mobile devices, including for the purpose of recording or filming a meeting, is subject to no interruptions, distractions or interference being caused to the PA or Induction Loop systems, or any general disturbance to proceedings. The Chairman may ask for mobile devices to be switched off in these circumstances.

It is requested that if you are not using your mobile device for any of the activities outlined above, it be switched off or placed in silent mode during the meeting to prevent interruptions and interference with PA and Induction Loop systems.

*Thank you for your co-operation*

***Note: This meeting may be filmed for live or subsequent broadcast via the Council's internet site - at the start of the meeting the Chairman will confirm if all or part of the meeting is being filmed. The images and sound recording may be used for training purposes within the Council.***

***Generally the public seating areas are not filmed. However by entering the meeting room and using the public seating area, you are consenting to being filmed and to the possible use of those images and sound recordings for webcasting and/or training purposes.***

*If you have any queries regarding this, please contact the representative of **Legal and Democratic Services** at the meeting.*

## **1. OPEN FORUM - PUBLIC QUESTIONS**

Before the formal Committee session begins, the Chairman will invite questions from members of the public attending the meeting. Where possible questions will receive an answer at the meeting, or a written response will be provided subsequently.

## **2 APOLOGIES FOR ABSENCE**

To receive any apologies for absence and notices of substitutions from Borough members under Standing Order 39.

## **3 MINUTES OF PREVIOUS MEETING**

(Pages 1 - 6)

To approve the Minutes of the previous meeting as a correct record.

## **4 DECISION TRACKER (FOR INFORMATION)**

(Pages 7 - 10)

This report updates the committee on the progress of decisions that have been made at previous meetings.

## **5 DECLARATIONS OF INTEREST**

To receive any declarations of disclosable pecuniary interests from Members in respect of any item to be considered at the meeting.

Notes:

- In line with the Relevant Authorities (Disclosable Pecuniary Interests) Regulations 2012, declarations may relate to the interest of the member, or the member's spouse or civil partner, or a person with whom the member is living as husband or wife, or a person with whom the member is living as if they were civil partners and the member is aware they have the interest.
- Members need only disclose interests not currently listed on the Register of Disclosable Pecuniary Interests.
- Members must notify the Monitoring Officer of any interests disclosed at the meeting so they may be added to the Register.
- Members are reminded that they must not participate in any item where they have a disclosable pecuniary interest.

## **6 CHAIRMAN'S ANNOUNCEMENTS**

To receive any Chairman's announcements.

## **7 PETITIONS**

To receive any petitions in accordance with Standing Order 65 or letters of representation in accordance with the Local Protocol. An officer response will be provided to each petition / letter of representation.

One petition has been received from Mr Armstrong on behalf of Heath Mews Ripley residents:

We the undersigned on the petition request that some action is taken with regard to speed in the locality of Ripley, Portsmouth Road

between Georgelands and the Burnt Common roundabout. In conjunction with the ongoing planned work at Junction 10 we need to achieve a 30MPH speed limit for this part of our village.

Thank you for your time and please advise us the best way forward.

## **8 PUBLIC QUESTION TIME**

To receive any questions from Surrey County Council electors within the area in accordance with Standing Order 66.

## **9 MEMBER QUESTION TIME**

To receive any written questions from Members under Standing Order 47.

One member question has been received from Councillor Angela Goodwin:

At our meeting in September 2017, members discussed the options to improve pedestrian safety on Bridge Street, Guildford. Please provide the latest timeframe for these safety works / new raised road tables to be carried out.

## **10 EARLY HELP PRIORITIES FOR GUILDFORD (EXECUTIVE FUNCTION)**

(Pages 11 - 26)

Surrey County Council has been working together with partners across the county and in Guildford to transform the system of early help that supports children, young people and families who are in need. We need to do this to both improve outcomes for local families and also address more effectively a number of the demand pressures we are facing across the public sector in Surrey.

To achieve this we are bringing together all partners who care about children and young people in local communities to provide the best possible support, through new Local Family Partnerships (LFPs). This report provides local Members with an update on the new model that Surrey County Council and partners have been developing for early help for the county overall and how this is progressing locally in Guildford.

## **11 LOCAL ENTERPRISE PARTNERSHIP LOCAL GROWTH FUND 3 TRANSPORT SCHEMES IN GUILDFORD - 'UNLOCKING GUILDFORD' CONSULTATION OUTCOME (EXECUTIVE FUNCTION FOR INFORMATION)**

(Pages 27 - 52)

This report presents the details of the consultation held on the package of projects known as "Unlocking Guildford", which was previously discussed at the December 2017 Local Committee. The works will be primarily funded by the Enterprise M3 Local Enterprise Partnership (EM3 LEP) with match funding from Guildford Borough Council, the Environment Agency and other sources. The consultation closed on 4 March and a high level analysis of the results has been undertaken. In general there is support for each of the projects and many comments to take into account as each element progresses towards business case submission and then detailed design.

**12 HIGHWAYS UPDATE (EXECUTIVE FUNCTION FOR DECISION)** (Pages 53 - 60)

This report provides an update on the 2017/18 programme of highway improvement and maintenance works funded by this committee, an update on other projects in the local area such as Tunsgate highway works and an update on New Pond Road Railway Bridge, as well as details of the budgets allocated to the committee in 2018/19 and recommendations on expenditure of the same.

**13 CABINET MEMBER FOR HIGHWAYS - UPDATE (FOR INFORMATION)** (Pages 61 - 116)

The Cabinet Member is attending the committee to improve communications and to provide information of works in the local area.

**14 FORWARD PLAN** (Pages 117 - 118)

The Forward Programme of reports for the Local Committee for 2018/19.



**DRAFT**

Minutes of the meeting of the  
**Guildford LOCAL COMMITTEE**  
 held at 7.00 pm on 13 December 2017  
 at Council Chamber, Guildford Borough Council, Millmead House, Millmead,  
 Guildford, Surrey, GU2 4BB.

**Surrey County Council Members:**

- \* Mr Keith Taylor (Chairman)
- Mr Mark Brett-Warburton
- \* Mr Graham Ellwood
- Mrs Julie Iles
- \* Mr Matt Furniss
- Mrs Angela Goodwin
- Mr David Goodwin
- Mrs Marsha Moseley
- \* Mrs Fiona White
- Mr Keith Witham

**Borough / District Members:**

- Borough Cllr Paul Spooner (Vice-Chairman)
- Cllr David Bilbe
- \* Cllr Nils Christiansen
- \* Borough Councillor Nigel Kearse
- Borough Councillor Julia McShane
- \* Borough Councillor Tony Phillips
- \* Borough Councillor Mike Piper
- Borough Councillor David Reeve
- Borough Councillor David Wright

\* In attendance

---

**17/17 OPEN FORUM - PUBLIC QUESTIONS [Item 1]**

Nigel Burke from the Guildford Bicycle User Group asked an informal question.

He said that the group was supportive of the Sustainable Movement Corridor but commented that a significant proportion of the investment will be going into the road infrastructure to assist car users which can increase traffic.

Have you considered prioritising active travel modes such as walking and cycling at all locations at once rather than doing the work in stages such as walking and cycling?

The Transport Strategy Project Manager responded that:

## ITEM 3

The additional capacity created by the work on the roads and junctions will help bus movements as well general traffic. The works to the Tesco round about are being prioritised at the moment, active travel will be prioritised as much as possible and the walking/cycling route between the Surrey Research Park and Guildford Station is also being improved. We cannot treat the entire route because if we widen the path on Gill Avenue we would need to dig this up later when we come to widen the road.

Members commented that air quality and traffic fumes were a concern and asked whether it was possible to do the whole thing in one go. Members also stated that it was important to encourage people to use the buses, that the Tesco round about works were a good idea and would hopefully help with air quality.

### **18/17 APOLOGIES FOR ABSENCE [Item 2]**

Apologies were received from Councillors: Keith Witham, Angela Goodwin, David Goodwin, Julie Iles, Mark Brett-Warburton, Marsha Moseley, David Reeve, Julia McShane and Paul Spooner who had been delayed at another meeting.

### **19/17 MINUTES OF PREVIOUS MEETING [Item 3]**

The Guildford Local Committee agreed the draft minutes as a true reflection of the previous meeting.

### **20/17 DECISION TRACKER (FOR INFORMATION) [Item 4]**

The report was provided to update Members on progress with Decisions made by the Local Committee. The Chairman and Vice- Chairman had recently updated it to ensure that it was still relevant.

### **21/17 DECLARATIONS OF INTEREST [Item 5]**

There were no declarations of interest of made.

### **22/17 CHAIRMAN'S ANNOUNCEMENTS [Item 6]**

The Chairman updated Members that the deadline for Members Allocation bids had been extended to the 31 January 2018, but encouraged Members to work with organisations putting in funding applications to submit them to the Support Officer in good time.

### **23/17 PETITIONS [Item 7]**

No petitions had been received.

### **24/17 PUBLIC QUESTION TIME [Item 8]**

No public questions had been received.

### **25/17 MEMBER QUESTION TIME [Item ]**

One Member question had been received from Councillor Adrian Chandler, Guildford Borough Council, on behalf of a member of the public concerning

maintaining roadside trees. The question and response were sent out as a Supplementary Agenda. The member of the public thanked the Highways officers for a full response.

**26/17 ANNUAL PARKING REPORT (EXECUTIVE FUNCTION FOR DECISION)  
[Item 10]**

Members considered the Annual Parking report which presented the performance of all parking services and made recommendations to change a number of on street restrictions to support expansion of the car club and improve traffic flow.

**The Local Committee (Guildford) agreed:**

- (i) to note the contents of Annexe 1 the Parking Annual Report for 2016-17
- (ii) formally advertise its intention to create an amendment order to convert the four bays referred to in paragraph 2.7 and shown in Annexe 2 in to bays for use by a car club car at any time. To also agree that if there are objections to the proposals which cannot be resolved that these are determined by the Parking Manager in consultation with the Chair, Vice Chair and Divisional Member but if there are no objections that the order is made.
- (iii) to agree to advertise formally the proposal to create an amendment order for further no waiting at any time restrictions in Chinthurst Lane as set out in paragraph 2.14 and Annexe 3. To also agree that if there are objections to the proposals which cannot be resolved that these are determined by the Parking Manager in consultation with the Chair and Vice Chair but if there are no objections that the order is made.

**REASONS:**

To provide alternatives to individual car ownership and allow access.

**27/17 LEP LGF3 TRANSPORT SCHEMES IN GUILDFORD INCLUDING  
OUTCOME OF PUBLIC CONSULTATION ON SUSTAINABLE MOVEMENT  
CORRIDOR: WEST (EXECUTIVE FUNCTION) [Item 11]**

The report presented the package of projects which was introduced at the previous Local Committee on 19 September 2017. It was proposed that the projects are consulted on with the public in January 2018, with the exception of the Sustainable Movement Corridor: West (SMC West) which has already been consulted on in September 2017, in order to enable that project to commence sooner. These works will be primarily funded by the Enterprise M3 Local Enterprise Partnership (EM3 LEP) with match funding from Guildford Borough Council, the Environment Agency and other sources. The results of the public consultation on the SMC West transport project and the recommended elements which are to be included in the LEP bid were also described in the report.

Members thanked the Transport Strategy Project Manager and team for their hard work and everybody that engaged with the (SMC West) consultation. Members commented that timing is important in order to link all the transport improvements together. Members also commented that the projects will give people more transport

## ITEM 3

options and they will not need to use their cars especially those going to and from the Surrey Research Park and Guildford Train Station.

The Transport Strategy Project Manager responded that:

The projects will give people more transport options and there will be less reliance on private car use especially those going to the Surrey Research Park, the University of Surrey and the Town Centre.

It was raised whether there was any possibility of a link from the A3 to the Research Park. The Transport Strategy Project Manager informed Members that Highways England aren't keen on adding a junction however improvements being made will help to get traffic off A3. The Chairman informed the committee that as the LEP projects consultation will start on 8 January 2018 and the Transportation Task Group are to view and agree the consultation material, prior to consultation they will deal with this by e-mail.

### **The Local Committee (Guildford) agreed to:**

- (i) Acknowledge the results of the public consultation on the Sustainable Movement Corridor West.
- (ii) Propose that the recommended measures for the Sustainable Movement Corridor: West are taken forward to business case submission.
- (iii) Note that the proposed consultation period for the remaining schemes commences in January 2018 and agree that the Area Highways Manager in consultation with the Transportation Task Group and the Project Manager (Transport Policy) view and agree the consultation material, prior to consultation.

### **REASONS:**

To enable Members to assess the public response on the SMC West project and provide their feedback and approval of the content of the project for a Business case application to the EM3 LEP be submitted.

To enable Members to share the information with constituents during the consultation period.

## **28/17 HIGHWAYS UPDATE (FOR INFORMATION ONLY) [Item 12]**

The report provided an update on the 2017/18 programme of highway improvement and maintenance works funded by this committee. It also provided an update on other centrally funded projects being promoted in the local area. The updates in the report included: the trial at Walnut Tree Close, Tunsgate highway works, planned works to B3000 New Pond Road Railway Bridge, Compton, the A31 Farnham Road Railway Bridge and the passenger facilities building at Onslow Park and Ride site.

The Local Committee (Guildford):

- (i) noted the capital works completed and expenditure to date.
- (ii) noted the ongoing revenue works being carried out.

Reasons:

The committee is not asked to make any decisions at this meeting, rather the report gives an update of progress on highway works in the current financial year.

**29/17 FORWARD PLAN (FOR INFORMATION) [Item 13]**

Members noted the Forward Plan of reports.

The Chairman informed Members that he had an offer from Highways England to attend another meeting in the early new year to update on the proposals and consultation for the Wisley junction of the M3, Members were in support of them coming along.

The Members asked the Chairman to speak up for the Local Committee Highways Funding with the Cabinet as they felt that this was a good use of resident's money.

Meeting ended at: 7.25 pm

---

**Chairman**

This page is intentionally left blank

# Local / Joint Committee Decision Tracker

This tracker monitors progress against the decisions that the Local Committee has made. It is updated before each committee meeting. (Update provided at 07/03/2018).

- Decisions will be marked as 'open', where work to implement the decision is ongoing.
- When decisions are reported to the committee as **complete**, they will also be marked as 'closed'. The Committee will then be asked to agree to remove these items from the tracker.
- Decisions may also be 'closed' if further progress is not possible at this time, even though the action is not yet complete. An explanation will be included in the comment section. In this case, the action will stay on the tracker unless the Committee decides to remove it

Meeting Date	Item	Decision	Status (Open/Closed)	Officer	Comment or Update
13 Dec 2017	10	<p>To formally advertise an amendment order to convert four parking bays for use by a car club car. If there are objections which cannot be resolved these will be determined by the Parking Manager in consultation with the Chair, Vice Chair and Divisional Member but if there are no objections that the order is made.</p> <p>To advertise an amendment order for further no waiting at any time parking restrictions in Chinthurst. If there are objections which cannot be resolved these will be determined by the Parking Manager in consultation with the Chair and Vice Chair but if there are no objections that the order is made.</p>	Open	Andy Harkin, GBC	Representations are currently being considered.

13 Dec 2017	11	<p>Propose that the recommended measures for the Sustainable Movement Corridor Transport schemes: West are taken forward to business case submission to the Local Enterprise Partnership.</p> <p>Note that the proposed consultation period for the remaining transport schemes commences in January 2018 and agree that the Area Highways Manager in consultation with the Transportation Task Group and the Project Manager (Transport Policy) view and agree the consultation material, prior to consultation.</p>	Open	Rob Curtis	<p>A bid to the Enterprise M3 Local Enterprise Partnership will be made later in 2018 for the main portion of funding to deliver the improvements.</p> <p>The Area Highways Manager in consultation with the Transportation Task Group and the Project Manager (Transport Policy) viewed and agreed the consultation material, prior to consultation. The consultation ran from 22 January- 4 March 2018.</p>
19 Sept 2017	9	Implement the approved amendment to the Definitive Map of Rights of Way to include the prohibition of all vehicles on parts of Byways Open to All Traffic Nos. 518 & 519. (Following the highways plans being updated and a drainage plan having been agreed)	Open	Steve Mitchell	Drainage plan for BOAT 518 and 519 to be drafted by SCC Countryside Access Team following discussions with GBC and developer of Minley Nursery site and site on northern side of BOAT 518.
19 Sept 2017	10	Guildford On-Street Parking Review: Changes agreed to be advertised and implemented as Annex 3 of the report but not those relating to Pewley Hill (upper) and Tormead Road	Open	Kevin McKee / Andy Harkin	To be implemented in early 2018
19 Sept 2017	12	The concept of a 'Quiet Lane / Unsuitable HGV' pilot zone in Shere Rural Area be progressed when funding available.	Open	Jeff Wilson	The proposals have now been taken to both Waverley and Mole Valley Local Committees at the end of 2017. Waverley agreed to the proposals whilst Mole Valley could not support the proposal as they



					did not wish to actively encourage HGV traffic to use the B2126. They did however express a desire for further engagement on the proposed initiatives and a parish-led workshop, facilitated by the Area of Outstanding Natural beauty (AONB) office, is planned to take place in April.
19 Sept 2017	14	Bridge Street: Proposed raised tables (Option B in the report) to be progressed, from central SCC funds.	Open	Duncan Knox, Frank Apicella	Bridge Street/Onslow Street road table scheme - the drawings will be finalised this month (March 2018), and construction is scheduled for July-September 2018.
19 Sept 2017	15	North Street: Progress the implementation of the road table in North Street.	Open	Frank Apicella	The Transportation Task group has proposed that the North Street Scheme be included in the Highways work budget for 2018/19 this will be considered by the Local Committee on 21 March.
19 Sept 2017	15	B3000 New Pond rd Railway Bridge, Compton: Ensure communications on the work on the Bridge go out to the public.	Closed	Highways Communications/Area Highways Manager	An update on the diversion route was provided at the December 2017 Committee. Public events have been held and the committee have received updates at each committee.
6 July 2017		Chairman to continue to campaign for the inclusion of highways schemes previously identified by the committee to be carried out.	Open	Cllr Taylor	This is an ongoing piece of work and schemes have been discussed by the Transportation Task Group in early March and proposals will come to the 21 March committee.
13 Dec 2016	6	Cllr Ellwood to liaise with Mr White regarding raising issues with Aldi	Open	Cllr Ellwood	

**Items on the decision tracker for consideration by the Transportation Task Group:**

19 Oct 2017 & 6 March 2018		Walnut Tree Close Update	Open	Rob Curtis	Update in Highways report went to December 2017 Committee. A further update was given to the Transportation Task Group (TTG) on 6 March 2018.
19 Oct 2017 & 6 March 2018		Highways Schemes go through prioritised schemes and provisionally allocate budget the proposals will come to the 21 March committee.	Open	John Hilder/Frank Apicella	TTG prioritised schemes and provisionally allocated budget on 6 March for consideration by the Committee on 21 March.

**SURREY COUNTY COUNCIL****LOCAL COMMITTEE (GUILDFORD)****DATE: Wednesday 21 March 2018****LEAD OFFICER: Ben Byrne, Head of Early Help and Family Services****SUBJECT: Early Help priorities for Guildford****DIVISION: Guildford****SUMMARY OF ISSUE:**

Surrey County Council has been working together with partners across the county and in Guildford to transform the system of early help that supports children, young people and families who are in need. We need to do this to both improve outcomes for local families and also address more effectively a number of the demand pressures we are facing across the public sector in Surrey.

The Children and Young People's Partnership has the following overall vision: children and young people are happy, healthy, safe and confident in their future. In support of this vision, early help means providing support as soon as a problem emerges, at any point in a child's life, from foundation years through to teenage years. This is based on an understanding that it is better to identify and respond to need and signals of risk for children and families before these become more difficult to reverse.

To achieve this we are bringing together all partners who care about children and young people in local communities to provide the best possible support, through new Local Family Partnerships (LFPs). By sharing our resources and integrating the support we provide to families we will reduce duplication and improve the reach and effectiveness of our work for families.

This report provides local Members with an update on the new model that Surrey County Council and partners have been developing for early help for the county overall and how this is progressing locally in Guildford.

**RECOMMENDATIONS:****The Local Committee (Guildford) is asked to:**

- (i) Provide feedback on the latest early help developments in Guildford, including proposed early help priorities for re-commissioning and the location of Local Family Partnerships
- (ii) Endorse the Local Committee representatives to the local Early Help Advisory Board, for the remainder of 2017/18 and 2018/19

**REASONS FOR RECOMMENDATIONS:**

We want Local Members to be informed about the proposals that we have been developing in partnership for the early help system in Surrey. We believe these

proposals will help us realise better outcomes for children and young people within the early help resources we have available. We also know however that early help is most effective when it is planned and delivered locally, so we are seeking the advice of the Local Committee to inform our identified local priorities.

## **1. INTRODUCTION AND BACKGROUND:**

- 1.1 Early Help means providing support as soon as a problem emerges, at any point in a child's life, from foundation years through to teenage years. We know that it is better to identify and respond to need and indications of risk for children and families early, before these become more difficult to reverse.
- 1.2 Whilst most children and young people in Surrey achieve good outcomes without the need for early help services, too many do not. Surrey was criticised in the 2014 Ofsted safeguarding inspection for its fragmented Early Help offer which left too many children waiting too long to receive the help they needed. The subsequent Department for Education Improvement Notice requires the county council to "*develop and implement a cohesive, collaborative Early Help offer delivered jointly by all partners*".
- 1.3 In response to this, to support better safeguarding decision-making and to ensure children receive the right help at the right time, Surrey established a Multi-Agency Safeguarding Hub (MASH) and four Early Help Co-ordination Hubs (EHCHs) in October 2016. As a result of the new arrangements more than 1,000 children are now receiving Early Help following referral to the MASH or step-down from Children's Service's each month.
- 1.4 Feedback from Ofsted's latest monitoring visit on 31 October and 1 November 2017 highlighted that the Council has made improvements in Early Help, due to work to review early help services, analyse need, establish Early Help Hubs and co-locate early help staff with those from statutory Children's Services in the MASH. However, it also highlighted significant concerns that "thresholds are not yet appropriately or consistently applied" and "an increase in demand for early help support has resulted in delays in the early help coordination hubs progressing referrals for the allocation of services".
- 1.5 As Ofsted's feedback suggests, Surrey County Council in isolation does not have the capacity to meet all of the demands for Early Help in Surrey. It is only by transforming the way we and other partners, who value Surrey's children as much as we do, work together that we can achieve the scale of impact we need, both to improve outcomes for children and families, and reduce demand for statutory services across the public sector in Surrey.
- 1.6 In Surrey, our partnership Early Help transformation is already well underway. In 2016, Surrey County Council implemented a number of service changes to improve its offer of proactive, appropriate, timely and preventative early help for children referred into Surrey Children's Social Care. In early 2017, the Council launched Surrey Family Services, with the aim of bringing together professionals working across early years and children's centres, the Family Support Programme, the Youth Support Service and the Community Youth Work service, in joined-up district and borough teams.
- 1.7 Partners have worked together to understand the early help needs of children and families locally, developed a shared vision for early help and designed a new model for the whole early help system to realise this ambitious vision for

early help – Local Family Partnerships. There is collective agreement between many partners that Local Family Partnerships are the model that will transform the early help system in Surrey and allow Surrey to realise its ambitious partnership vision.

- 1.8 Local Family Partnerships bring together a network of key stakeholders in a community who are involved in supporting the well-being and resilience of children and families. These include statutory, voluntary, faith and community organisations (including businesses) who either provide preventative activities for children and families or are responsible for targeted and specialist interventions to meet our statutory duties. All these organisations contribute to the Early Help offer and by binding them together at a local level we will provide a rich network of integrated provision to children and families in each Local Family Partnership. It is anticipated that each district and borough will be sub-divided into up to five Local Family Partnership areas, the locations of which will be locally determined, in response to the local needs of children and

## Local Family Partnership

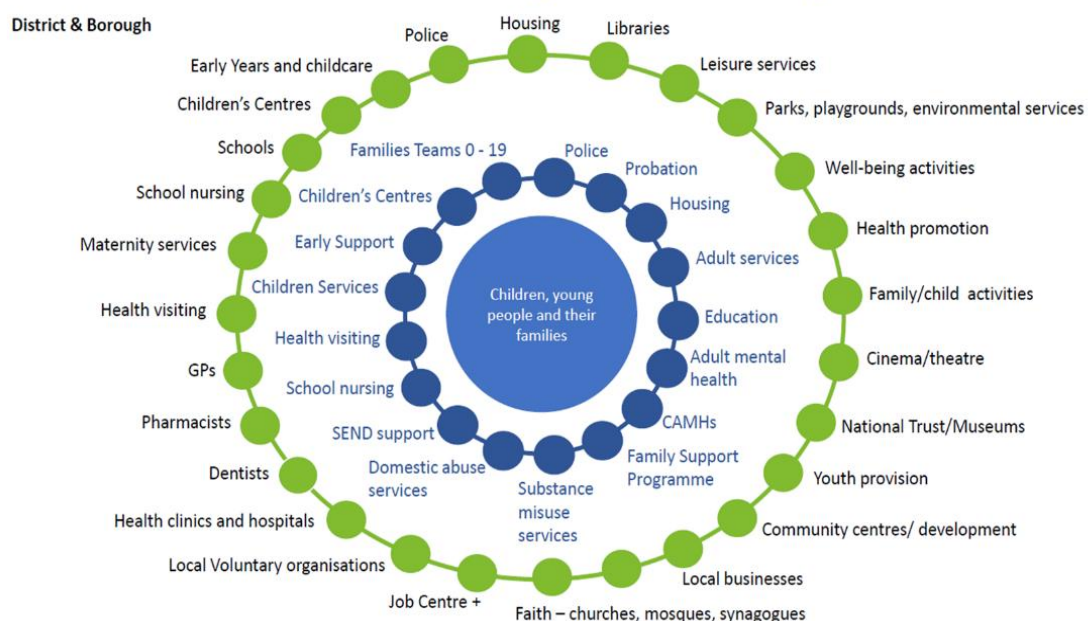

families.

- 1.9 The figure above is a visual representation of the sources of support for families that exist within communities and therefore Local Family Partnerships. The central (blue circle) represents targeted interventions, which tend to focus on particular individuals or families, and the outer (green) circle represents organisations that contribute to universal support in a community. The County Council has responsibility for ensuring that a cohesive and co-ordinated Early Help offer is in place with partners who make up the 'blue circle' of targeted Early Help. The 'green circle' is led by District and Borough Councils and is fundamentally about a place-based approach to ensuring that the local environment, infrastructure and services are conducive to family well-being. In this model strong partnerships are required at a local level between universal services, the voluntary, community and faith sector and the local authorities. The particular opportunity within Local Family Partnerships will be through developing effective local relationships between services that will enable the easy movement between targeted support for children and families at times of

[www.surreycc.gov.uk/guildford](http://www.surreycc.gov.uk/guildford)

## ITEM 10

particular need and back into the 'green circle' of preventative support (and vice versa as required).

- 1.10 Working through the Early Help Advisory Board in Guildford, we are identifying and developing the locations of Local Family Partnerships and a number of key local priorities that will inform the future development of the local early help system. These priorities will specifically feed into the external re-commissioning of early help services that is currently underway, to award new grants and contracts to local providers from April 2019.
- 1.11 Guildford's Early Help Advisory Board met for the first time in November 2017 and has met twice since. The meeting has representation from health, schools, police, local faith and voluntary groups, local SCC services and from members. Since the first meeting, the board has agreed to develop 4 Local Family Partnerships, in the West, Central, East and Rural areas of Guildford. The board has completed an Early Help Plan for the borough, agreeing on 5 priorities to work towards over the coming years, based on an analysis of local needs. This plan is included in Annex 1.
- 1.12 Surrey County Council will align its resources to directly support this new partnership Early Help System in Surrey. Although a key aspect of the Local Family Partnership is that it allows for local flexibility, it is also important that there is countywide consistency in relation to key early help services provided by the County Council. In overall terms, this will be ensured through standard structures and processes for County Council services across Surrey, as well as developing transparent, needs-led approaches to allocate resources in districts and boroughs in response to the identified level of need. Some examples of the indicators that could be employed include the: level of deprivation; number of referrals to MASH; and number of children with special educational needs and/or disabilities.
- 1.13 There are three main strands of the County Council's contribution to Early Help that form part of the Early Help transformation. These are:
  - a. Surrey Family Services;
  - b. Surrey's Children's Centres; and
  - c. Externally-commissioned contracts and grants for local services.
- 1.14 SCC's in-house delivery of Early Help comes primarily through Surrey Family Services. In May 2017 Family Services brought together a number of different teams and programmes including: Youth Support Service; Community Youth Work; Family Support Programme; Children's Centres; practitioners from the Early Years and Childcare Service; and the Early Help Co-ordination Hubs, which together coordinate and deliver a significant proportion of the Early Help across the county. Importantly, Family Services also has responsibility for young people identified as requiring a statutory Child in Need social work service and those over the age of eleven who require an Edge of Care service. As part of the new Early Help operating model, Family Services staffing will be restructured to align to the Local Family Partnership model in the course of 2018 and a new locally integrated youth work offer will be developed with districts and borough, the voluntary sector and young people who use the services.
- 1.15 SCC also commissions Surrey's 58 children's centres, which are delivered by schools and voluntary sector providers. In the course of 2018 the County

Council will work with current providers, wider stakeholders and the public to re-shape a new children's centre offer to commence in April 2019. In developing the new model, we are committed to working with our partners in schools and the voluntary sector, who have a track record of delivering high quality early years services, to design a model which fulfils the children's centre core purpose around health, well-being and early education.

- 1.16 Through a new model for children's centres, we will continue to support children to have the best start in life, whilst also integrating services delivered into the wider 0-19 Local Family Partnership model. This may well involve developing greater flexibility of staffing at a Local Family Partnership and/or borough or district level to ensure services are resilient and resources are deployed where they are most needed. It is also envisaged that this new model of delivery will free providers from the requirements of children centre 'designation' as mandated in (now suspended) Department for Education guidance. Many local authorities already choosing this route to afford greater local flexibility to provide the services that are required to meet need. Through better integrating the children's centre offer with the work of other services, freeing providers to focus upon outcomes rather than process, and requiring children's centres to work together across a district/borough, the declining SCC revenue resource can go further in providing Early Help to meet the local needs of children and families.
- 1.17 Finally, SCC commissions a range of preventative and family support services from external partners, including jointly commissioned domestic abuse outreach services, primarily from the local voluntary sector. SCC's commissioning intentions for children are described in **SCC's Child First Commissioning Plan 2017**. The Early Help services will be recommissioned from April 2019 onwards as part of a joined-up pathway for families to meet local needs. The **Early Help Commissioning Plan** is currently being developed with partners, drawing on local priorities as identified by Early Help Advisory Boards, with a view to publication in March 2018.
- 1.18 **Working across Programmes:** There are many interdependencies between the Early Help Transformation and other change programmes ongoing across the Children Schools and Families directorate. The work to enhance Surrey's Early Help offer is an important component of the Safeguarding Improvement Programme and has already seen considerable progress in the ability to step-up to and step-down from Children's Services social work intervention. Work is also ongoing to align Early Help and SEND Transformation Programmes to ensure SEND services are embedded in the Local Family Partnership model. A further significant opportunity exists through ensuring Local Family Partnerships properly integrate with the health sector particularly through alignment of the Early Help Transformation with the Sustainability and Transformation Plans (STPs) for health.

## **2. ANALYSIS:**

- 2.1 A summary local early help needs analysis for Guildford, based on the data we have available, has been attached as Annex 1. This data informed local conversations about what is most important in Guildford to identify locations of Local Family Partnerships and local early help priorities.

## **3. OPTIONS:**

## ITEM 10

- 3.1 The Early Help Advisory Board is in the process of identifying the Local Family Partnerships in Guildford. We are currently considering:

**West** – Ash, Tongham, Normandy, The Pilgrims and Pirbright

**Central** – Westborough, Stoughton, Onslow, Worplesdon and Shalford

**East** – Stoke, Friary & St. Nicolas, Holy Trinity, Christchurch, Merrow and Burpham

**Rural** – Lovelace, Send, Effingham, Tillingbourne and Clandon & Horsley

- 3.2 In addition, they have identified the following key local early help priorities:

- To improve family stability
- Promote adult and child mental health support
- Address financial issues and promote funding for families
- To promote successful transitions from adolescent to adult services
- Domestic abuse – to take a multi-agency approach

- 3.3 The Local Committee is invited to provide feedback to the Early Help Advisory Board in relation to the local priorities they have identified.

### **4. CONSULTATIONS:**

- 4.1 Between November 2016 and March 2017 Surrey County Council and the 11 District and Borough Councils led on Local Early Help Partnership Events, engaging over 1,000 practitioners and other stakeholders. These events resulted in a shared development of the vision for Early Help Transformation Programme and the Local Family Partnership model and agreement to establish local Early Help Advisory Boards. These local Early Help Advisory Boards help to ensure a locally led implementation of the Early Help model. Initial activities include deciding priorities for their area including locations of local family partnerships.

- 4.2 Early Help Stakeholder events were held in Guildford on the 30<sup>th</sup> of November 2016 and the 11<sup>th</sup> of January 2017. The events were attended by representatives from schools, health, borough and county councils officers and members, voluntary groups and faith groups. Attendees were asked to contribute to an assessment of the needs of families in the area.

Currently stakeholders and community partners are supporting and developing the formation of the borough's Local Family Partnerships.

- 4.3 The Local Committee has identified two committee members to sit on the Early Help Advisory Board, to provide member input into local discussions and a link back to the committee. The members identified were Angela Goodwin and David Wright. It is intended that, as per recommendation iv,



these members will continue in their role for the remainder of 2017/18, and for 2018/19.

- 4.4 At a county level, the Early Help Transformation Programme Board, chaired by the Lead Member for Children, brings together senior partnership stakeholders on a six-weekly basis to oversee and shape key decisions relating to the transformation plans.
- 4.5 In September and October 2017, a series of workshops were held to further develop the blueprint for the Local Family Partnership model.
- 4.6 The Early Help Case for Change was considered and endorsed by the Children and Education Select Committee on Friday 17 November 2017.
- 4.7 A Surrey Family Services staff consultation for County Council staff started in January 2018 to consider proposals for service restructure.
- 4.8 Further partner and user engagement and subsequent public consultation will be required in 2018 to implement changes to community services resulting from the new Early Help operating model.

#### **5. FINANCIAL AND VALUE FOR MONEY IMPLICATIONS:**

- 5.1 There are no financial and value for money implications in relation to this report.

#### **6. EQUALITIES AND DIVERSITY IMPLICATIONS:**

- 6.1 A programme Equality Impact Assessment is being developed which will include all the key areas of the programme and their potential impacts on residents and staff. Evidence will be gathered during key consultation periods with the staff and public which are planned for 2018:
  - a. A Family Services staff consultation taking place in January 2018 will develop a key summary of impacts and actions relating to the impacts of the restructure. The initial EIA inputs to date based on early staff engagement and engagement with other stakeholders including the unions on the restructure can be seen in the attached first draft of the Programme EIA.
  - b. Once approval to commence work on the Children's Centre project has begun an EIA will be developed to provide a key summary of the impacts and actions relating to the potential re-design of Children's Centres.
  - c. An EIA has been drafted to support the re-commissioning of external early help services in Surrey.

#### **7. LOCALISM:**

- 7.1 The Local Family Partnership model is about building the resilience and wellbeing of individual children and young people, and the families and communities that they are part of.
- 7.2 Guildford's Local Family Partnerships overall aim is to bring together highly networked communities, who play a part in shaping their local area, to ensure

those who need it have the early help they require. We foresee a positive impact for communities, children and families, as support and resources will be targeted and accessed locally.

**8. OTHER IMPLICATIONS:**

Area assessed:	Direct Implications:
Crime and Disorder	Set out below.
Sustainability (including Climate Change and Carbon Emissions)	No significant implications arising from this report.
Corporate Parenting/Looked After Children	Set out below.
Safeguarding responsibilities for vulnerable children and adults	Set out below.
Public Health	Set out below.

8.1 Crime and Disorder implications

Through establishing new Local Family Partnerships in Guildford, partners will work together better to prevent young people becoming involved in offending and anti-social behaviour and be able to provide holistic support to families where crime is an issue.

8.2 Corporate Parenting/Looked After Children implications

Effective Early Help has the potential to reduce the negative outcomes and experiences that can lead to children coming into care and thereby has the potential to reduce the number of children in the Council’s care.

8.3 Safeguarding responsibilities for vulnerable children and adults implications

The new Early Help operating model supports the Council to achieve key improvements in safeguarding vulnerable children. As the parents of these children are also often known to Surrey Adult Services the programme is being developed with colleagues in Adult Services and will have additional benefits for vulnerable adults through the development of Local Family Partnerships.

Ongoing developments to ensure that the Multi Agency Safeguarding Hub (MASH) and the Early Help Co-ordination Hub processes are integrated will have an improved impact on the timeliness and effectiveness of case management for vulnerable children and families. MASH and Early Help Co-ordination Hub processes have recently been reviewed to support quality, consistency of decision-making and provide more timely access to Early Help services. The programme has been developed to enhance the services available both to prevent children requiring statutory intervention where this can appropriately be achieved and to provide a robust Early Help network to support children stepping down from social work and other specialist services.

#### 8.4 Public Health implications

The Early Help proposals have been developed with Public Health colleagues and support the Council's Public Health prevention priorities for children and families

### **9. CONCLUSION AND RECOMMENDATIONS:**

9.1 The Local Committee is asked to note the overall proposals to develop the early help system in Surrey, as well as the summary of proposed changes to Surrey County Council's contribution to early help

9.2 **The Local Committee (Guildford) is asked to:**

- a. Provide feedback on the latest early help developments in Guildford, including proposed early help priorities for re-commissioning and the location of Local Family Partnerships
- b. Endorse the Local Committee representatives to the local Early Help Advisory Board, for the remainder of 2017/18 and 2018/19

### **10. WHAT HAPPENS NEXT:**

10.1 The Early Help Strategy will be presented to the County Council's Cabinet at the February meeting.

10.2 Feedback from the Local Committee will be taken away by the Local Family Service Team Manager to be shared with the Early Help Advisory Board and commissioners across different public sector organisations.

10.3 Members are invited to contribute to public consultation later in the year in relation to changes to other aspects of the early help system. In particular, a public consultation about proposals for changes to children's centres is planned for July, August and September 2018. The scope of this consultation may also be broadened out to include other aspects of early help provision.

10.4 Surrey Family Services will be launching its new staffing structure by October 2018 which will reflect new ways of working required within the early help system.

10.5 Members input and support in building the Local Family Partnership Networks will be valued throughout the first phase of implementation in 2018.

10.6 It is currently planned that the County Council's Cabinet will be asked to make a number of decisions relating to early help transformation in November 2018, with plans in place to implement any service changes by 1 April 2019.

---

#### **Contact Officer:**

Vicky Harris

## ITEM 10

Vicky.harris@surreycc.gov.uk  
07968834760

### **Consulted:**

Early Help Advisory Boards  
Members of the Early Help Transformation Board  
Local partners and stakeholder  
Surrey County Council Commissioners

### **Annexes:**

Annex 1 – Borough Early Help Plan  
Annex 2 – Early Help Advisory Board Terms of Reference

### **Sources/background papers:**

- Not applicable
-

Population		Ward / SOA Analysis	Summary of need (inc.key trends)	Ernst Young Findings / Recommendations	Voice of the child & young people ...
0-4 year olds	8030 (16.6%)	<p><b>IDACI Rank 2015</b> (where 1 is most deprived) : Rank 5  <b>LSOA, 30% most deprived nationally:</b> Ash Wharf, Worplesdon, Westborough, Stoke</p> <p>Some households in Ash Vale, Ash South, Tongham and some parts of Worplesdon and Stoke are, on average, within the most deprived 40% nationally</p>	<ul style="list-style-type: none"> <li>23% of referrals received by MASH related to domestic abuse (DA), 18% were regarding mental health concerns about a child and 9% related to physical abuse</li> <li>187 incidents of DA incidents reported between March 2016- April 2017 impacted on 0-24 year olds</li> <li>Children in the early years make less progress in Guildford than in most Surrey borough and districts.</li> <li>At the Foundation Stage, children who have English as an alternative language make less progress in Guildford than in any other borough/ district in Surrey.</li> <li>The number of young people arrested and linked to offences is higher in Guildford than the Surrey average, including the number drug related offences.</li> </ul>	<ul style="list-style-type: none"> <li>There are 481 families in need of targeted and universal plus early help provision in the borough.</li> <li>They recommended locations for 2 family hubs and 4 satellites</li> </ul>	<p><u>What challenges do you face as a child living in the borough?</u></p> <p>‘Trying to fit’</p> <p>‘Always stressed due to examines’</p> <p>‘Always being hungry’</p> <p>‘Young people suffering from mental health issues, a lot of my friends and people at school have a lot of mental health issues – depression. But there is no support unless you end up in hospital cos of it’.</p> <p>‘Not knowing my future and if I am going to be ok’</p> <p>‘Pressure to be perfect’</p> <p>‘Our mental health is impacted cos of being bullied and trying to fit in’. Is it worse for us cos of social media – adults done get it, social media can break you’</p> <p>‘I am quite lonely’</p> <p>‘Trains and travel is too expensive’</p> <p>‘No local or cheap activities to do in our area’</p> <p>‘Large expectations making us anxious’</p> <p>‘I think many young people face problems in Park Barn, like stress of being popular and anxiety’</p> <p>‘Many teens face bullying and forms of sexism’</p> <p><u>Can you identify any resources that are missing in the borough?</u></p> <p>‘Affordable gyms for young people’</p> <p>‘Support groups for young people with mental health issues’</p> <p>‘A place for young people to go who are in crisis’</p> <p>‘Things to do with families where we live’</p> <p>‘Better bus routes and more bins’</p>
5-9 year olds	8775 (18.2%)				
10-14 year olds	8076 (16.7%)				
15-19 year olds	9348 (19.3%)				
20-24 year olds	14,170 (29.3%)				
Total no. of c& yp SEND (0-25)	48,339				
Free school meals	2316				
Families in Need (targeted and universal plus)	2467				
Child in Need	481				
CP	1930				
NEET YP	158				
	17				

Early Help Outcomes for Guildford	Priorities for development (Early Help Offer)	What works locally ....
-----------------------------------	---	-------------------------

<ul style="list-style-type: none"> <li>Build resilience in carers, parents and the community to become more self-sustaining</li> <li>Increase positive and supportive family relationships and community networks</li> <li>Improve school readiness and achievement - to reduce the number of exclusions, increase school attendance, reduce NEET young people and to support early learning of disadvantaged 2 and 3 year olds.</li> <li>Children to achieve their full potential</li> <li>Adults and children to be supported to take control of their mental health</li> <li>Develop new ways of working in the borough, to make sure appropriate responses are given to a child, young person or family at the time when difficulties or vulnerabilities are identified.</li> <li>To support children and young people to make informed decisions about their lives and relationships</li> <li>Reduce the harm caused to children and young people through domestic abuse, parental alcohol/drug abuse and mental health</li> </ul>	<ul style="list-style-type: none"> <li><b>To improve family stability</b> Pre and post diagnostic support with children with additional needs. Support for Parents and Carers around: Parenting adolescents - focusing upon sexualised behaviour and mental health Modern day parenting - focusing upon social media, secure attachment, parenting resilience, supporting education Promoting attainment and achievement for children</li> <li><b>Promote adult and child mental health support</b> Adult mental health services to be involved with family partnership decision- making Support for parents to access adult mental services Drop-ins for parents with children with mental or emotional health needs To offer parents the support that enables them to embed the changes for their child</li> <li><b>Address financial issues and promote funding for families</b> To promote services that address benefits and finances (including debt) Promote feet funding and how to apply Promote the 30 hours childcare funding.</li> <li><b>To promote successful transitions from adolescent to adult services</b> Supported Living – additional support for vulnerable young people entering adult services. Collaborative partnership working and joint planning.</li> <li><b>Domestic abuse – to take a multi-agency approach</b> Promote outreach services. To support children around healthy relationships, parental alcohol/drug abuse and mental health</li> </ul>	<ul style="list-style-type: none"> <li>Guildford has the lowest proportion of children born with a low birth weight.</li> <li>The proportion of children who are children in need due to abuse or neglect is lower than average for Surrey.</li> <li>Overall the attainment scores at Key Stage 4 are higher than the Surrey and the national averages.</li> </ul>
---	---	--

This page is intentionally left blank

# Local Early Help Advisory Boards

## Terms of Reference

Version 3- August 2017

## ITEM 10

These terms of reference are intended to provide some direction for Local Early Help Advisory Boards recognising they will evolve in slightly different ways but with a core defined purpose. These terms of reference are currently draft and will be agreed by the end of July, following initial meetings of Local Early Help Advisory Boards.

### **Scope**

The scope of the Local Early Help Advisory Board is the local implementation of the early help delivery model.

### **Purpose**

To bring together a partnership in each borough or district invested in developing a coherent local early help offer and manage the successful delivery of this offer. By coming together the partners will hold a collective responsibility for decisions and support the successful delivery of this offer.

### **Key responsibilities**

- Have strategic oversight of the co-ordination and effectiveness of the local early help offer.
- Provide support and challenge to the development of the local early help offer
- Support the development of a joined up local plan which prioritises early help needs and outcomes
- Work collectively with local operational networks to implement a local plan
- Maintain an oversight of the development and effectiveness of the Local Family Partnership
- Support the development of local early help commissioning plans and participate in commissioning processes to deliver a local joined up early help offer
- Work locally to identify gaps in provision regarding early help and to identify and mitigate against risks
- Support the practitioners' networks including co-ordinating training and development opportunities in accordance with local need
- Help capture the voice of families, children and young people
- Communicate with key local stakeholders outside of the meeting to raise awareness of the local early help offer and developments.
- Update the Early Help Transformation Programme Delivery Group via the Strategic Leads for Young People and Families, escalating any risks as required.
- Provide an annual report to the local or joint committee on early help.

### **Chair**

Each Local Early Help Advisory Board will appoint an appropriate chair from their membership.

### **Ways of working**

- Meeting agendas will be agreed by the Chair and the Families Service Manager
- Agendas will be circulated to members of the Local Early Help Advisory Board prior to the meeting
- If it is not possible for a member to attend, they should nominate a substitute representative to attend with delegated authority to make decisions on behalf of their organisation.
- Minutes of this meeting will be kept by the Families Service Manager and agreed by members of the group
- Members will provide updates to the board on actions and key developments in their area

### **Frequency of Meetings and Venues**

Meetings will be held at least quarterly at suitable venues across the borough or district.



## Meeting Membership

The membership of boards will vary across boroughs and districts, however there are some core principles for the membership of each board:

- Membership should be as local as possible and key local partners should be represented to ensure they can be consulted with and are involved in making decisions.
- Members need to be able to represent the broad views of the key delivery groups and be able to speak on their behalf about good practice and local need.
- Members need to impact on the establishment and delivery of early help rather than measure accountability
- With any Surrey County Council representation it should be considered whether they are required as a core member or if discussions could take place outside of the meeting (e.g. Families Service representation should be limited to the borough Families Service Manager)
- There should not be more than 15 members to allow for effective discussion and decision making

Representation should consider:

- Borough or district council
- Secondary education
- Primary education
- Children's Centre
- Two elected representatives from the local/joint committee
- Police
- Health
- Job Centre Plus
- Housing
- Voluntary, Community, Faith Sector
- Young people
- Parent groups

This should not be seen as exhaustive

This page is intentionally left blank

**SURREY COUNTY COUNCIL**

**LOCAL COMMITTEE (GUILDFORD).**

**DATE: 21 March 2018**



**LEAD OFFICER: Robert Curtis, Transport Strategy Project Manager**

**SUBJECT: Local Enterprise Partnership Local Growth Fund 3  
TRANSPORT SCHEMES IN GUILDFORD – “Unlocking  
Guildford” Consultation outcome**

**DIVISION(S): ALL**

**SUMMARY OF ISSUE:**

This report presents the details of the consultation held on the package of projects known as “Unlocking Guildford”, which was previously discussed at the December 2017 Local Committee. The works will be primarily funded by the Enterprise M3 Local Enterprise Partnership (EM3 LEP) with match funding from Guildford Borough Council, the Environment Agency and other sources. The consultation closed on 4 March and a high level analysis of the results has been undertaken. In general there is support for each of the projects and many comments to take into account as each element progresses towards business case submission and then detailed design.

**RECOMMENDATIONS:**

**The Local Committee (Guildford) is asked to:**

- (i) Note the consultation content and summary of results and that the proposed projects are to be submitted as part of a full business case to the EM3 LEP for funding and, if successful, subsequent detailed design and implementation.

**REASONS FOR RECOMMENDATIONS:**

To ensure that Local Committee is content with the projects in the “Unlocking Guildford” package prior to submission to the EM3 LEP.

**1. INTRODUCTION AND BACKGROUND:**

- 1.1 Six projects have been provisionally agreed between the Enterprise M3 Local Enterprise Partnership (EM3 LEP), Guildford Borough Council and Surrey County Council for the 3<sup>rd</sup> tranche of the Local Growth Fund (LGF3). The EM3 LEP has provisionally allocated a total value of £12.5M towards the six projects. Funding will be awarded by the EM3 LEP subject to the submission of a successful business case for each project to demonstrate economic viability and contribution to growth in the borough.

- 1.2 The current allocation of these funds for each project is set out below – this may be subject to change as the projects are still at feasibility stage so cost requirements are to be refined. Additionally the match funding, whilst provisionally agreed, requires sign off from the relevant sources.

	LEP BID	Match Funding	Total Cost
Quality Bus Corridors	3,210,000	1,240,000	4,450,000
Sustainable Movement Corridor West	2,725,000	1,125,000	3,850,000
Blackwater Valley Hotspots phase 1 (South) and phase 2 (North)	1,965,000	1,965,000	3,930,000
A31 Highway Resilience Corridor	2,400,000	1,312,500	3,712,500
Guildford Town Centre Approaches	700,000	333,000	1,033,000
Guildford Flood Alleviation	1,500,000	5,100,000	6,600,000
<b>Transport Total</b>	<b>12,500,000</b>	<b>11,075,500</b>	<b>23,575,500</b>

- 1.3 The package as a whole has been developed over the last two years and an overarching strategic case has been produced to demonstrate to the EM3 LEP that the package will deliver the required benefits for Guildford Borough. The objectives of the package described in the strategic case are:
1. To provide improved access by all transport modes but with priority for public transport and sustainable travel from the town centre into, and out of, west Guildford.
  2. To create a sustainable transport corridor between the town centre railway station and Royal Surrey County Hospital/Research Park and improve access between the town centre, the main residential areas and Slyfield Estate through improved public transport.
  3. To relieve traffic pressure on strategic routes into Guildford currently subject to very significant peak hour congestion.
  4. To ensure the transport infrastructure is available during periods of flooding and to remove constraints on development of a number of sites in the town centre due to flood risks.
  5. To create the conditions to ensure that growth can be delivered and sustained across Guildford.
- 1.4 The public should be consulted on each project to allow local residents, businesses and visitors to shape each project and provide feedback. As reported previously at the meeting of the December 2017 Local Committee, the business case for the Sustainable Movement Corridor West (SMC West) was consulted on in autumn 2017. The full business case for this project has since been submitted to the LEP and we await their decision regarding the funding.
- 1.5 The business cases for the remaining five projects are still due to be submitted to the EM3 LEP. The consultation on these schemes was carried out from 22 January to 4 March to enable public engagement to take place prior to the business case submission.

- 1.6 The panels used in the consultation are provided in Annex 1, these describe each of the projects; it should be noted that the A31 Resilience scheme is included within the A331 hotspots scheme for the consultation as there was very little additional information for the project to merit inclusion as a separate project on the panels.
- 1.7 Three consultation events were held around the borough of Guildford on Thursday 8 February and Friday 9 February 2018, comprising two exhibitions at The Friary and one at Tongham Community Centre.
- 1.8 The aim of these events was to enable people to talk to us about the Unlocking Guildford proposals so that they could find out more information, allow officers to gain evidence of support and feed their suggestions into the development of the project. The objectives were:
- To get as many people as possible to complete the online survey
  - To get people to complete paper questionnaires at the exhibition or take them home and post them to us.
  - Raise awareness of the consultation and the project by handing out flyers.

<b>Dates</b>	<b>Exhibition open</b>	<b>Location</b>
Thursday 8 Feb	09:00 – 13:00	<b>The Friary</b> North Street, Guildford, GU1 4YT
Thursday 8 Feb	16:00 – 19:30	<b>Tongham Community Centre (Lounge Bar)</b> Poyle Road, GU10 1DU
Friday 9 Feb	14:00 – 18:00	<b>The Friary</b> North Street, Guildford, GU1 4YT

## **2. ANALYSIS:**

- 2.1 The consultation ran from 22 January to 4 March 2018.
- 2.2 In total over 300 people attended the three events and 255 people completed the questionnaire either online or on paper. In total, there were 279 written responses received.
- 2.3 A summary of the consultation and analysis of feedback can be found in Annex 2. The graph below shows the level of agreement expressed for each of the projects. It can be seen that over 50% of questionnaire respondents either agreed or strongly agreed with each of the schemes.

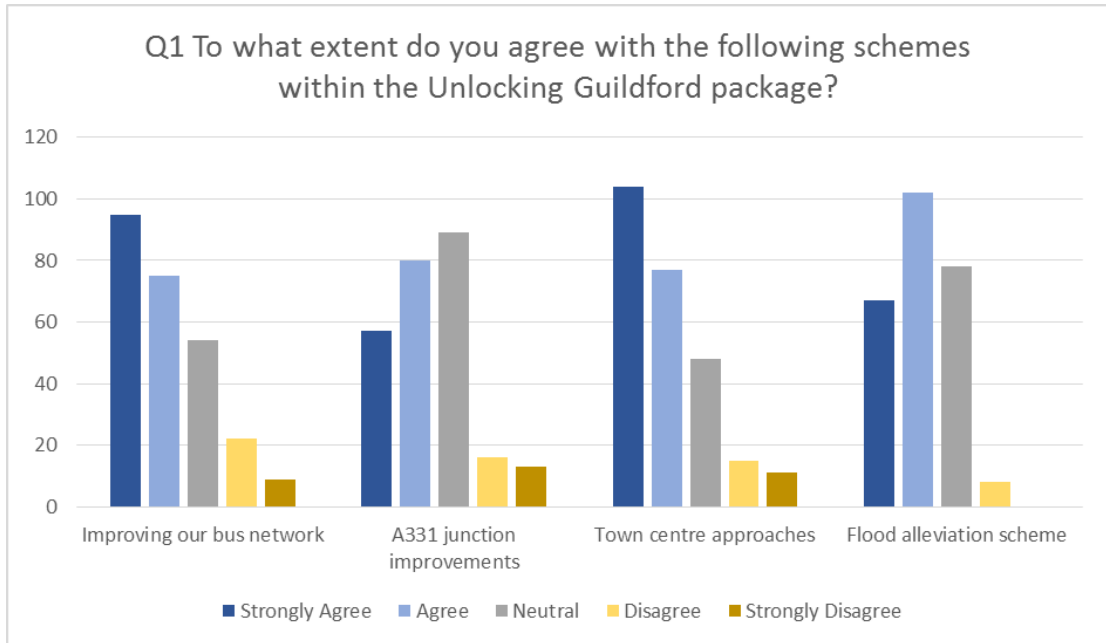

**3. OPTIONS:**

- 3.1 The package as a whole has been provisionally agreed with the EM3 LEP; the funding has been set aside for each of the schemes above, though there may be opportunity to move individual allocations between schemes as they are developed and more detailed cost estimates are produced.
- 3.2 The options are therefore related to whether any particular elements of a project are more effective than others in delivering the package objectives, and also whether there is strong opposition or difficulty in delivering some of the package. Since the consultation has not identified strong opposition to any of the schemes it is proposed that the package of schemes as a whole continue to progress as planned.

**4. CONSULTATIONS:**

- 4.1 The engagement period between 22 January and 4 March 2018 represents the public consultation for the package though there may be further consultation on a scheme-by-scheme basis where traffic orders are required or where there is any significant change to any project that would require further public consultation.

**5. FINANCIAL AND VALUE FOR MONEY IMPLICATIONS:**

- 5.1 Guildford Borough Council and Surrey County Council have allocated revenue budgets to the development of the business cases with the exception of the flood alleviation scheme, which is being submitted by the Environment Agency.
- 5.2 The majority of the capital funding is coming from the EM3 LEP. Each project requires match funding and each of the organisations providing the match will need to demonstrate that the funding is available before the EM3 LEP will provide the funding.

## **6. EQUALITIES AND DIVERSITY IMPLICATIONS:**

- 6.1 A full equality impact assessment will be completed for each project as part of the business case submission process.
- 6.2 For the consultation, groups and individuals were targeted based on previous experience and included dialogue with groups catering for individuals with protected characteristics. Flyers, posters and public exhibitions were used to raise awareness of the project to those in the area who are not easily contactable by email, the internet or social media channels.

## **7. LOCALISM:**

- 7.1 The proposals will affect all road users in the areas where amendments are proposed. The proposals were publicised as described and any comments received will be given careful consideration.

## **8. OTHER IMPLICATIONS:**

Area assessed:	Direct Implications:
Crime and Disorder	No significant implications arising from this report.
Sustainability (including Climate Change and Carbon Emissions)	Set out below.
Corporate Parenting/Looked After Children	No significant implications arising from this report.
Safeguarding responsibilities for vulnerable children and adults	No significant implications arising from this report.
Public Health	Set out below.

### Sustainability and Public Health Implications

- 8.1 Many of the proposed improvements are intended to help reduce congestion, the resultant journey times and pollution – particularly with regards to bus routes. The package may therefore positively impact public health through associated air quality improvements and encouraged modal shift towards bus use.
- 8.2 Although the schemes are not specifically aimed at cycling and walking, there will be road safety improvements and the designers will seek to improve pedestrian and cyclist facilities as part of the design, this will assist with modal shift and lead to associated health benefits.

## **9. CONCLUSION AND RECOMMENDATIONS:**

- 9.1 **The Local Committee (Guildford) is asked to:**

- (i) Note the consultation content and summary of results and that the proposed projects are to be submitted as part of a full business case to the EM3 LEP for funding and, if successful, subsequent detailed design and implementation.

**10. WHAT HAPPENS NEXT:**

*SMC West scheme*

10.1 The business case for the SMC West was submitted in January 2018 along with an overarching strategic case which covers all the schemes in the package. Both of these documents are currently being considered by the EM3 LEP. It is expected that there will be a decision on the funding in late March 2018.

*Quality Bus Corridors, Blackwater Valley Hotspots, Town Centre Approaches, A31 Resilience and Flood Alleviation schemes*

10.2 We plan to submit business cases for the five remaining schemes to the LEP for consideration at the end of April 2018. A secondary date in late June is available to submit any outstanding information. The final business case for each project will be developed incorporating comments and suggestion from the consultation where feasible and based on technical reasoning and assessment of affordability and deliverability.

---

**Contact Officer:**

Robert Curtis, Transport Strategy Project Manager, Guildford Borough Council & Surrey County Council (01483) 444904

**Consulted:**

Local Ward and Divisional Councillors

**Annexes:**

Annex 1 – Unlocking Guildford Consultation Panels  
Annex 2 – Unlocking Guildford Consultation Report

---



# UNLOCKING GUILDFORD

## MAKING IT EASIER TO GET AROUND GUILDFORD

**Guildford is set to experience significant change over the next 20 or so years. The borough's recently submitted local plan proposes around 14,000 additional homes together with major employment growth in the period up to 2034. We recognise that this growth is likely to place even more pressure on our roads and that it therefore must go hand in hand with positive action to improve the borough's infrastructure.**

**Our proposals to 'unlock' Guildford will help to ease traffic congestion, encourage more people to take the bus and will increase the town and its roads' resilience to flooding.**

We have developed a package of improvements worth approximately £20m. The Enterprise M3 Local Enterprise Partnership has provisionally allocated £12.5m towards the enhancements, the rest of the funding is expected to come from Guildford Borough Council, bus operators and the Environment Agency.

Once the consultation has closed, we will consider your feedback and finalise the proposed improvements. Guildford Borough Council and Surrey County Council will subsequently apply for funding for the improvements from Enterprise M3. If we're successful, construction work on the first set of improvements is likely to start in 2019 and would be completed in phases up until spring 2021.



### HAVE YOUR SAY

We'd like to know your thoughts and suggestions on our Unlocking Guildford proposals. Please complete a questionnaire online or at a public exhibition by Sunday 4 March 2018. Visit [surreycc.gov.uk/guildfordtransportschemes](http://surreycc.gov.uk/guildfordtransportschemes) or search online for 'Unlocking Guildford'.

For any questions regarding Unlocking Guildford please contact Zac Ellwood, Major Projects Portfolio Manager, at [zac.ellwood@guildford.gov.uk](mailto:zac.ellwood@guildford.gov.uk)

If you would like any of this information in a different version (for example, large print) please telephone 03456 009 009.



# UNLOCKING GUILDFORD

## IMPROVING OUR BUS NETWORK

**Buses are a vital mode of transport for the local area, carrying roughly five million passengers per year and connecting neighbouring towns and villages with Guildford. Every day 15,000 people travel on buses in Guildford, and these numbers are increasing each year.**



Delays to bus services make it difficult to meet timetables

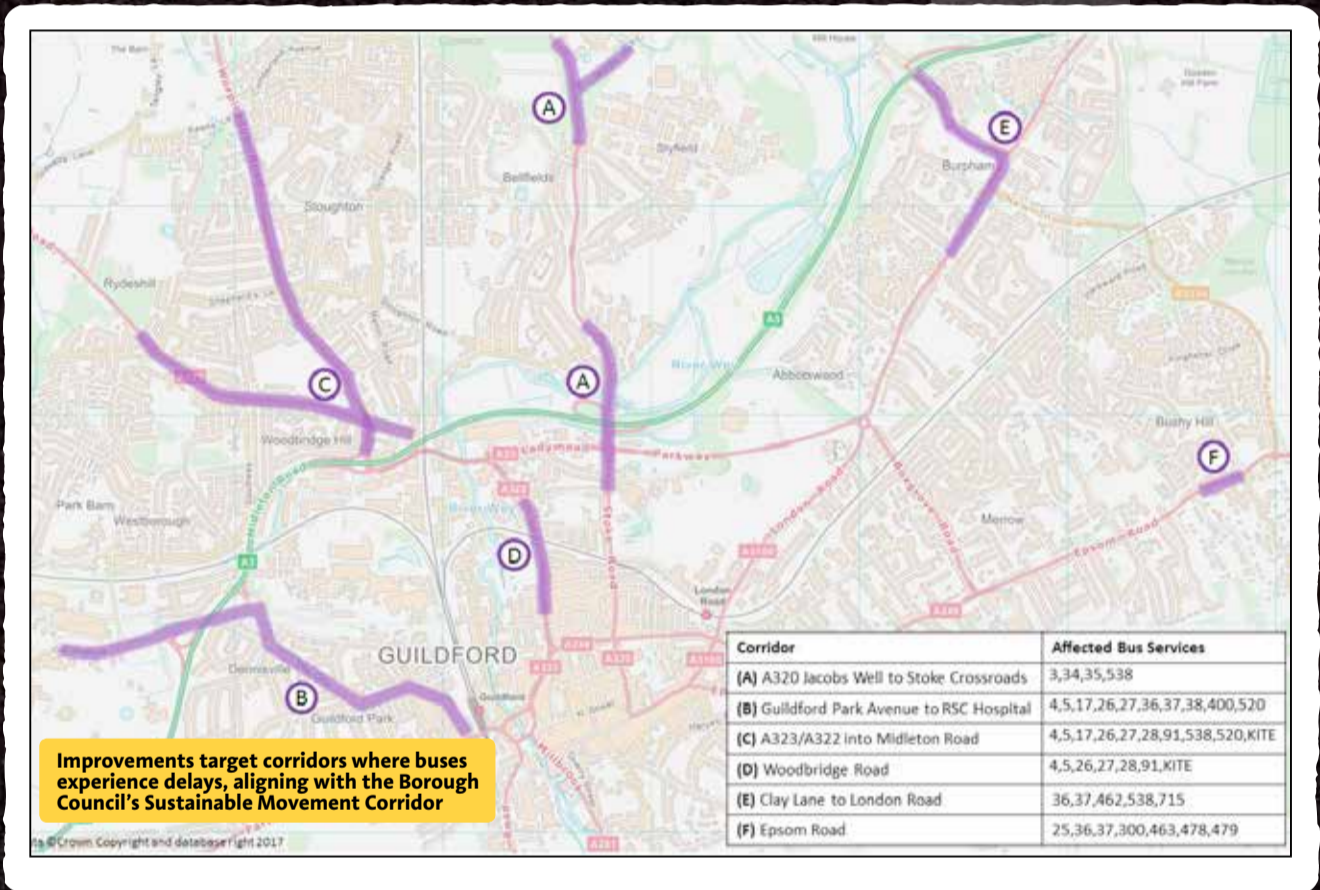

Improvements target corridors where buses experience delays, aligning with the Borough Council's Sustainable Movement Corridor

### Proposed improvements

We know that having reliable services are essential to passengers, as well as having access to accurate up-to-the-minute travel information. We also want to make sure that the key routes which serve Guildford and its surrounding towns have attractive, clean and well-lit passenger waiting areas, and are easily accessible with conveniently located bus stops.

These improvements could include:

#### Bus reliability and improved journey times

- Intelligent bus priority at traffic signals
- Junction improvements at bottlenecks which will benefit all road users
- Bus-friendly traffic management at pinch points where buses experience delay

#### Better passenger information

- High quality printed timetables, maps and fares information at bus stops
- Increased use of real time passenger information, with displays at bus shelters, shopping centres and at main employment centres
- Audible and visual next stop information on buses
- Bus arrival information through SMS text messaging

#### Improved passenger infrastructure

- New bus shelters with improved seating and lighting
- Improved pedestrian links between bus stops and key locations
- Upgraded bus fleets which are more comfortable for passengers
- An integrated smart and contactless ticketing system



# UNLOCKING GUILDFORD

## A331 BLACKWATER VALLEY RELIEF ROAD JUNCTION IMPROVEMENTS

Two junctions on the A331 Blackwater Valley Relief Road have long suffered from congestion, particularly during the weekday rush hours. As new residential development in the area is expected which will increase demand on the roads, the proposals aim to help the road network in Ash and Tongham and the surrounding area by improving the following junctions:

- 1. A31/A331 roundabout near Farnham:** Significant delays are caused by the high number of vehicles joining the roundabout from the A331 and heading towards Farnham. It also causes queues along the slip road back onto the A31 Hog's Back.
- 2. A331/A323 roundabout between Ash and Aldershot:** Both Oxenden Road and the A323 Aldershot Road in Ash suffer from congestion and queuing during peak periods. This is mainly due to the number of vehicles joining the roundabout from the west to travel along the A331, or into Aldershot from the A331.

### Proposed improvements

We are considering installing traffic signals on some approaches to the junctions which will help clear congestion. They might only need to be used during rush hours. During this work, we may also look to upgrade the drainage and road surface along the A31 Hog's Back. The improvements aim to deliver the following benefits:

- Quicker and more reliable journey times for vehicles joining the A331 from the A31 and using the A331/A323 roundabout.
- Improved road safety by reducing incidences of slip-road traffic queuing back onto the A31 and A331.

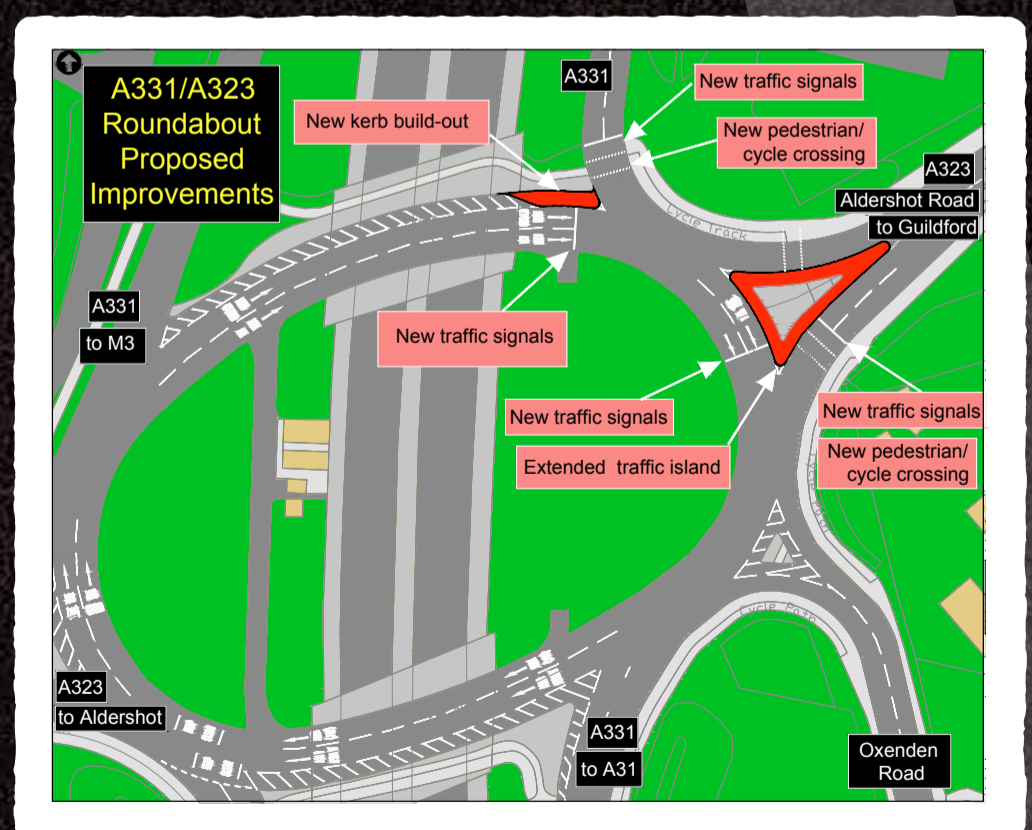
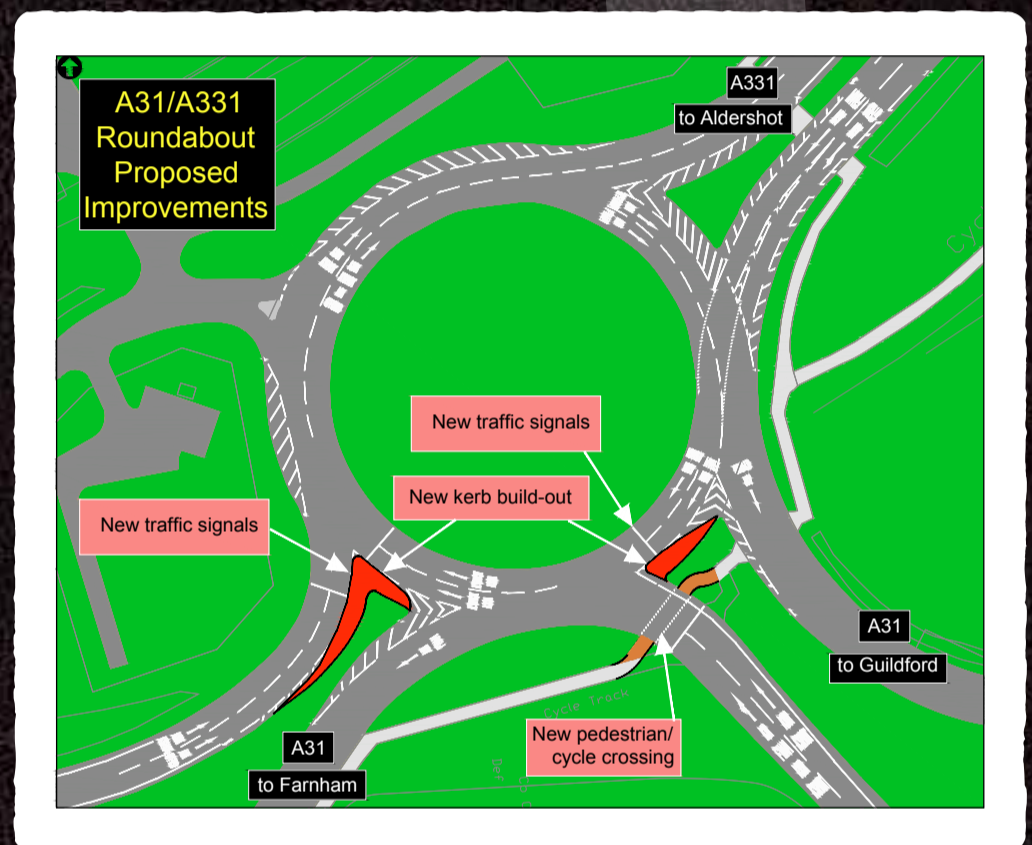

# UNLOCKING GUILDFORD

## TOWN CENTRE APPROACHES

Using a traffic management system with the latest technology will mean we're better equipped to manage the roads effectively and alleviate congestion. Without a new and upgraded system congestion is likely to get worse and journey times increase as roads get busier.



### Proposed improvements

We are planning to install and upgrade our traffic management systems to use the latest technology at the key locations where people decide which route they use to travel around Guildford.

This will enable us to react to traffic incidents in a number of ways, including:

- Variable message signs to inform drivers of a collision or congestion and direct them along less busy routes
- The ability to alter traffic light phasing to help clear queues of traffic

These measures will improve journey time reliability and allow for faster recovery after incidents.

## TOWN CENTRE FLOOD ALLEVIATION

The Environment Agency is leading a partnership including Surrey County Council and Guildford Borough Council to address flooding and help protect buildings. Guildford has a history of flooding, most recently in December 2013 when 92 properties flooded.



### Proposed improvements

Through a mixture of permanent and temporary flood defence walls, this scheme aims to reduce the risk of flood water entering homes and businesses, and disrupting transport links. It also supports the economic development and regeneration of the town centre. The improvements are expected to benefit key parts of the road network through Guildford town centre, including the A281 Millbrook.

The design approach aims to create a better place. It promotes connections between the town and the river and links communities with the environment, which will ultimately benefit both people and wildlife.



## Annex 2 - Consultation Report

### 1. Executive Summary

This report describes the process and high level analysis of the Unlocking Guildford public consultation undertaken during early 2018. The public consultation was a joint activity coordinated between Guildford Borough Council (GBC) and Surrey County Council (SCC).

The Unlocking Guildford package is expected to contain a number of discrete schemes that seek to address transport issues in and around Guildford. The responses received during the consultation will inform the development of these schemes and help us to understand the aspects that are of most importance to people. Additionally the feedback collected during the consultation period will help provide evidence to support the creation of business cases to be submitted for Local Growth Deal funding for each of the schemes.

An advisory six-week public consultation was held from Monday 22 January to Sunday 4 March 2018.

The consultation presented information, location diagrams and concept drawings on a number of schemes that would form part of the Unlocking Guildford package including:

- i. Bus network improvements
- ii. A331/A31 junction and link improvements
- iii. Town centre approaches
- iv. Town centre flood alleviation

The public were asked to consider the information provided and indicate their levels of support for each of the schemes, the extent to which they felt the proposals would be beneficial and any suggestions for improvement.

During the consultation period a total of 279 written responses were received via the following methods:

- **255** questionnaire responses
- **15** email responses
- **9** exhibition book comments

Additionally the public exhibitions received over 300 visitors, representing a very good level of engagement.

### 2. Wider Engagement

A series of activities were carried out to ensure that as many residents and organisations as possible could take part in the consultation, particularly existing users of the infrastructure and those located nearby or who would be affected by the proposals.

Web page: A central SCC web page was created as a centralised source of information regarding the consultation and exhibition, whilst also linking visitors to a questionnaire collecting feedback on the scheme. Information panels displaying detailed information on the scheme were provided on the website. A GBC web page was also created, including information that mirrored the SCC page and statements from GBC's Lead Councillor for Infrastructure and Governance, Cllr Matt Furniss and Cabinet Member for Highways, Colin Kemp.

## ITEM 11

The SCC web page received **2,594** visits during the six-week period, including **2,204** unique visitors.

**Email:** Notification of the consultation was communicated to various groups including: statutory consultees; local businesses and organisations; residents groups; members from county divisions, borough wards and parishes; environmental bodies; specific interest groups; and individuals who have declared an interest in receiving consultation notifications. Given that some of the A331 proposals were located in close proximity to the county boundary, communications were also shared with neighbouring local authorities and members. These bodies were identified through the: Surrey County Council's Local Transport Plan and Surrey Transport Review consultee lists; previous transport consultations in Guildford town centre and further channels of research. Organisations were also able to respond to the consultation via email to the SCC major schemes inbox.

**SCC engagement officers:** Notification of the consultation was relayed throughout contact networks via engagement officers to specific groups including schools, students, adult social care and disability networks. For example, schools within a close proximity to the proposals were notified of the consultation and asked to advertise the consultation to parents via ParentMail communications.

**Social media:** The consultation was promoted frequently on SCC and GBC social media channels including the Surrey Matters, Joint Committee and member Facebook and Twitter platforms.

**Online banners:** Advertising banners on the SCC and GBC homepage and intranet were posted at regular intervals throughout the consultation and directed interested users to the web page.



**Circulars:** Posters and flyers were displayed at key public locations near to the proposals in Guildford, Tongham and Ash. These included:

- Guildford bus station
- Guildford library
- G Live
- YMCA (Wharf Road)
- Electric Theatre
- Yvonne Arnaud theatre
- Ash youth centre
- Ash library
- Tongham Community Centre
- Tongham parade

**Press release:** A joint SCC and GBC [press release](#) was published to promote the consultation. The release included statements from GBC Lead Councillor for Infrastructure, Matt Furniss and the SCC Cabinet Member for Highways, Colin Kemp.

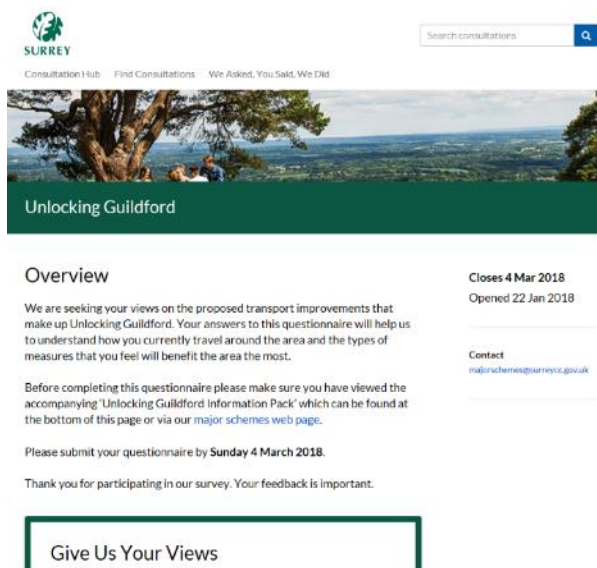

**Overview**

We are seeking your views on the proposed transport improvements that make up Unlocking Guildford. Your answers to this questionnaire will help us to understand how you currently travel around the area and the types of measures that you feel will benefit the area the most.

Before completing this questionnaire please make sure you have viewed the accompanying 'Unlocking Guildford Information Pack' which can be found at the bottom of this page or via our [major schemes web page](#).

Please submit your questionnaire by **Sunday 4 March 2018**.

Thank you for participating in our survey. Your feedback is important.

[Give Us Your Views](#)

**Closes 4 Mar 2018**  
Opened 22 Jan 2018

**Contact**  
[majorschemes@surreycc.gov.uk](mailto:majorschemes@surreycc.gov.uk)

**Local media:** The consultation was publicised to and received coverage within a dedicated article in [Get Surrey](#). The press release was picked up by local media outlets including [Eagle Radio](#).

**Questionnaires:** The majority of feedback was provided through a questionnaire designed specific to the package of schemes. Web users were directed to the Consultation Hub on 'Surrey Says' where they could complete the questionnaire online. Paper forms were also available so that respondents could return these either via post or at one of the exhibitions. All responses received will be considered further as part of the detailed design.

The format of the paper version of the questionnaire is available in Appendix A. The online Surrey Says questionnaire contained the same questions though in a slightly different format.

### 3. Direct engagement

**Exhibition:** Three staffed public exhibition events were held during the consultation period: including two events on Thursday 8 February and one event on Friday 9 February 2018 to enable individuals who might be more difficult to reach or not have access to the internet to take part in the consultation. Officers from Guildford Borough Council, Surrey County Council and Environment Agency were on hand at the exhibitions to discuss the proposals and take feedback.

The exhibition venues, The Friary Guildford and Tongham Community Centre, were chosen due to their proximity to the proposed improvements and ease of accessibility. The events covered morning, afternoon and evening periods to offer members of the public a wide range of opportunities to be able to view and discuss the proposals in person.

Over the course of the two days, approximately **306** visitors were received at the exhibitions. This figure is one of the highest visitor tallies for a 'Major Schemes' transport event over the past few years and shows a good level of interest and engagement.

A comment book was provided during the exhibition where visitors could provide additional written feedback.



**Stakeholder meetings:** SCC held meetings around the consultation period with stakeholder groups, such as bus operators, to get their targeted feedback on the scheme proposals where they would have a direct interest.

#### 4. Consultation response analysis

Further to the engagement methods described above, members of the public, businesses and other organisations were invited to respond and provide feedback on the Unlocking Guildford package of schemes.

##### Questionnaires

A total of 255 responses were received via questionnaire. Of this total, 239 questionnaires were received via the online survey with a further 16 submitted in paper format.

##### **‘Your views’ section (Q1-Q8)**

The following questions sought to understand how respondents currently use the transport infrastructure being targeted, the degree to which they support the proposals and suggestions they might have to improve upon the proposals.

##### **Q1 – To what extent do you agree with the following schemes in the Unlocking Guildford package?**

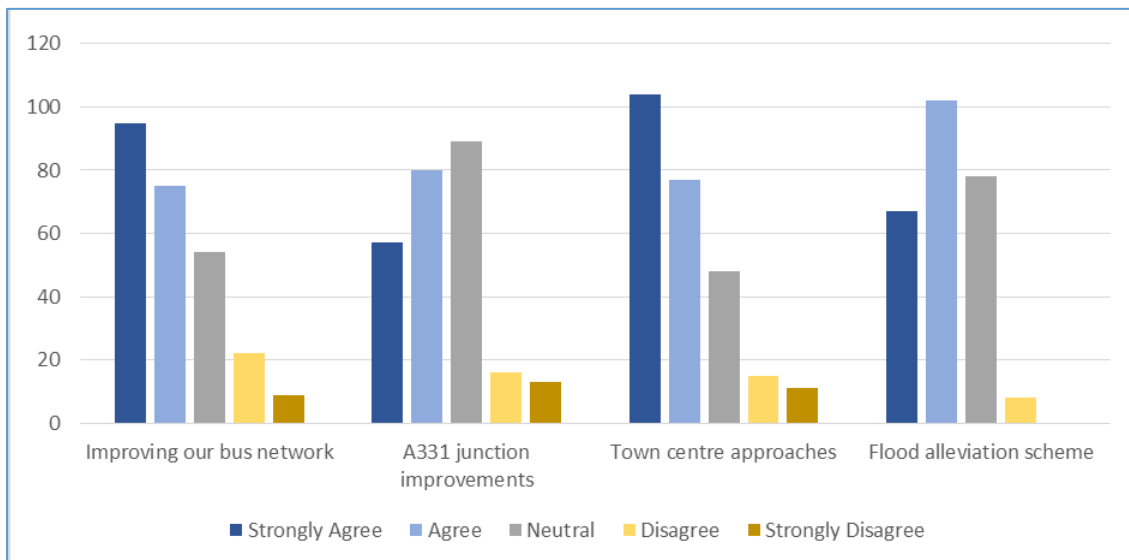

In general, all four of the schemes received a good level of support with over 50% of respondents indicating that they either ‘agreed’ or ‘strongly agreed’ with each of the schemes.

The bus improvements and town centre approaches schemes received the highest level of ‘strong agreement’ (95 and 104 respectively). The flood alleviation scheme was the least divisive amongst the four schemes, with no respondents indicating that they ‘strongly disagreed’ with the proposals.

The A331 junction improvements also received a good level of support with 137 respondents ‘agreeing’ or ‘strongly agreeing’ with the scheme. However, it should also be noted that ‘neutral’ accounted for the largest proportion of responses to the scheme. There are two themes that can be seen in the responses to later questions may provide an insight into why this is:

1. A large number of survey respondents indicated that they rarely or never travel through the two A331 junctions and therefore may not have felt informed as to whether the improvements were needed.
2. A number of text answers indicated that some respondents felt the proposed improvements did not go far enough or would not address other issues at the two junctions (e.g. pedestrian / cycle access).



**Q2 – How often do you travel by bus around Guildford?**

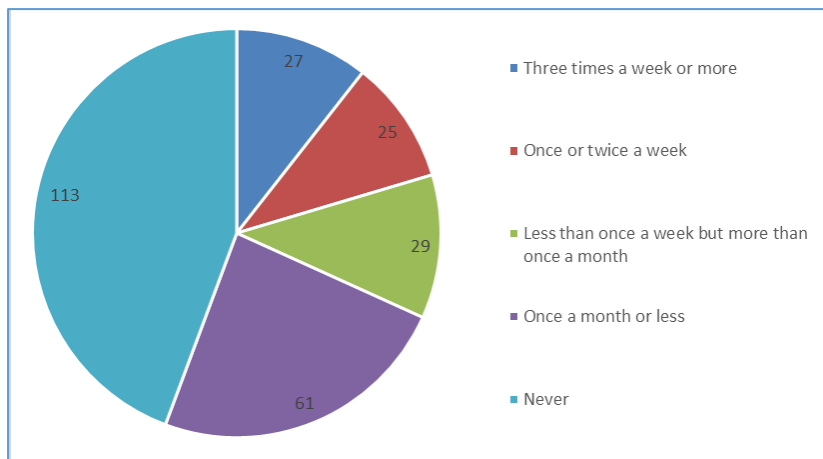

Around two thirds of the people who responded to the questionnaire indicated that they rarely (once a month or less) or never use the bus to travel around Guildford. The remaining third of respondents were fairly even split amongst the more frequent user categories.

Given that around 3.4% of Guildford residents commute via bus (7.5% nationally) according to the most recent census<sup>1</sup>, it would appear that the consultation achieved a good level of engagement amongst bus users to obtain feedback on the proposed bus improvements.

**Q3 – Would the proposed bus improvements make you likely to use the bus more often, or consider travelling by bus if you are not currently a bus user?**

Just under 40% of respondents indicated that the proposed improvements would make them likely to consider travelling by bus more.

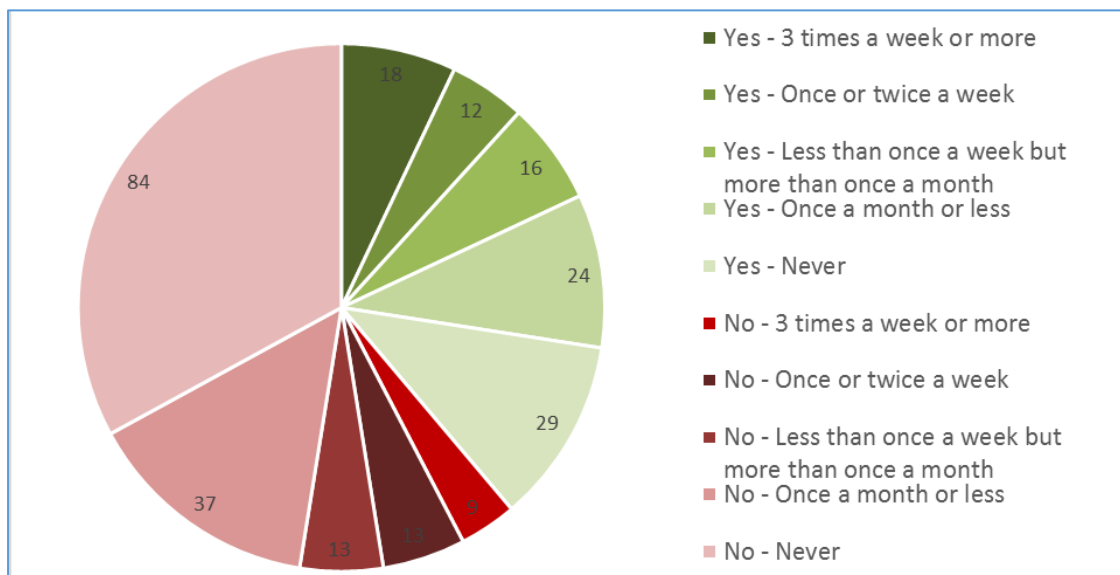

Focussing specifically on the respondents who identified themselves in Q2 as infrequent bus users ('Once a month or less' or 'Never'), 53 respondents, or 30% of this dataset, stated that they would consider travelling by bus based on the proposed improvements. This would indicate that the scheme has the potential to encourage modal shift towards greater bus use.

<sup>1</sup> 2011 Census data. Office for National Statistics.

## ITEM 11

**Q4 – If you feel there is something missing from the proposed bus improvements that would encourage more people to travel by bus around Guildford, please provide details below.**

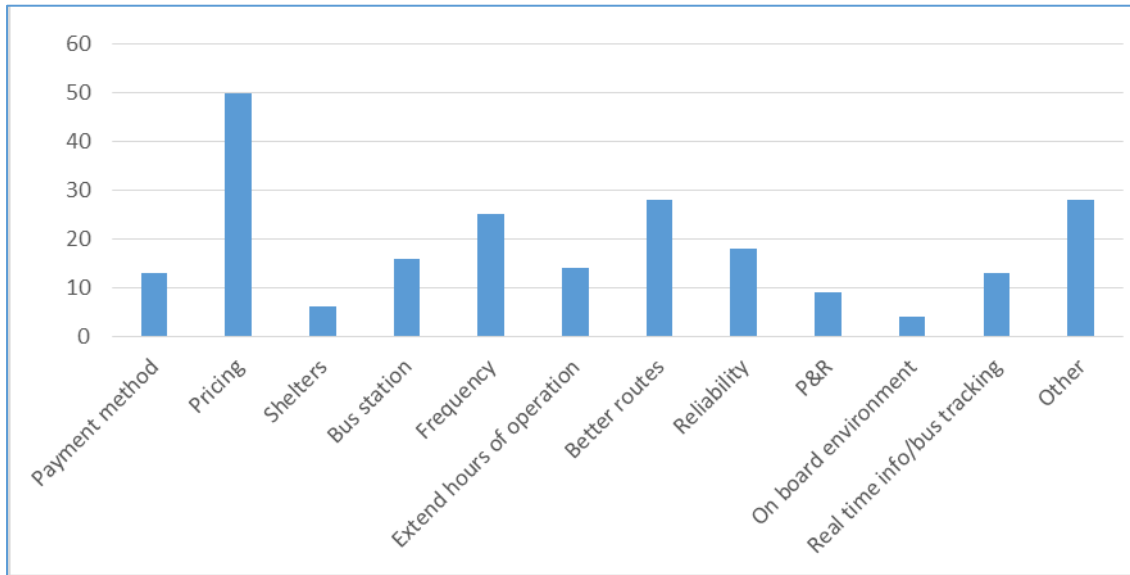

Q4 gave respondents the opportunity to identify bus improvements they believed would encourage greater patronage that were not included within the scheme proposals. Content analysis was carried out on the responses to extract common themes that were mentioned by multiple respondents. The following three themes were most frequently raised:

- **Pricing** – This theme covers a demand for cheaper bus fares and group / family discounts, particularly to encourage Park & Ride.
- **Better routes** – This theme covers a demand for increased coverage/number of overall bus routes and shorter 'more efficient' individual routes as well as suggestions such as express routes from farther afield.
- **Frequency** – This theme covers a demand for more regular bus services, particularly regarding Sunday provision and at peak commuting times.

'Other' themes that were suggested to increase bus usage included: greater integration of buses with the rail station; bus prioritisation and lane enforcement; and efforts to make the bus fleet less polluting.

**Q5 – How often do you travel through either of the two junctions targeted in the A331 Blackwater Valley Relief Road junction improvements?**

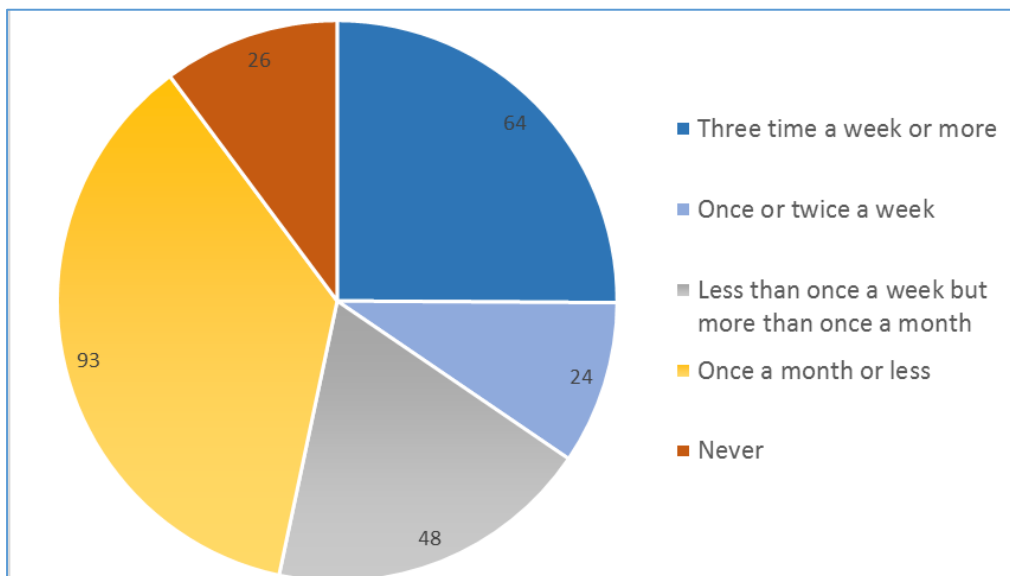

Over half of the respondents to the survey (136) used either the A31 or A323 junctions of the A331 more than once a month, and 35% used the junction at least on a weekly basis. It is felt that this represents a good level of user engagement, considering that the consultation concerned multiple schemes, rather than just the A331 junction improvements scheme.

Whilst public communications regarding the consultation was broadly distributed across the borough, a specific effort was made to engage residents in the Tongham / Ash area (including via public exhibition) in an attempt to obtain the views of people who would be closely impacted by the proposals.

**Q6 – To what extent do you feel that congestion is a problem that needs to be addressed at the following junctions?**

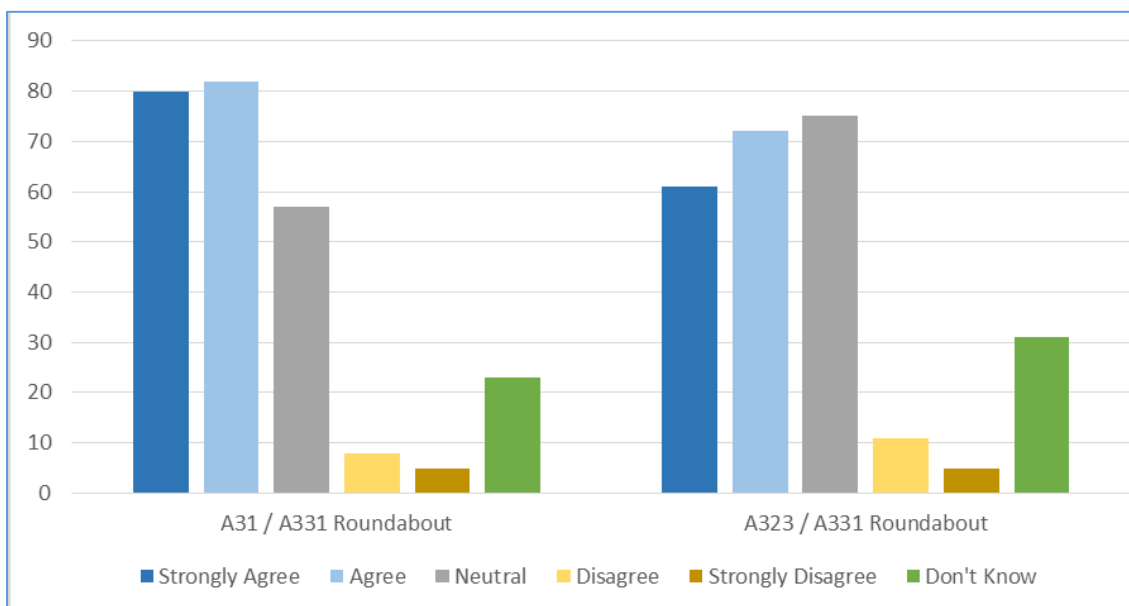

There was a general consensus amongst the responses to Q6 that congestion presents an issue at both the A31 and A323 junctions.

## ITEM 11

There was a slightly higher degree of agreement regarding the issue at the A31 junction, with around 64% of respondents ‘agreeing’ or ‘strongly agreeing’ that congestion is a problem there. 52% of respondents ‘agreed’ or ‘strongly agreed’ that congestion should be addressed at the A323 junction.

Similarly to Q1, a significant number of respondents neither agreed nor disagreed with the statement and many others stated that they ‘didn’t know’. This may be partly attributable to some survey respondents being unfamiliar with the two junctions.

### Q7 – Do you have any comments or suggestions regarding the proposals for either of the two roundabouts on the A331? If so, please give your views here.

This was an open question and so a variety of responses were received regarding the proposals for the A331 junction improvements. Content analysis was carried out on the responses to extract common themes that were mentioned by multiple respondents. In some cases more than one theme was identified by a single respondent. The following themes were seen to be raised most frequently on both roundabouts:

- **General support** – Responses that indicated general support for the proposals.
- **Improve pedestrian/cycle access** – Responses that indicated an opinion that the proposals should do more to integrate safe crossing facilities for pedestrians and cycles.
- **Minimal effectiveness** – Responses that indicated an opinion that the proposals did not go far enough or did not focus on the correct aspects to sufficiently alleviate congestion.
- **Design/signals concerns** – Responses that indicated an opinion that the overall design of the junction or introduction of signals would exacerbate congestion.
- **Focus on non-car modes** – Responses that indicated an opinion that congestion would be best addressed by focussing investment elsewhere on other modes of transport.

‘Other’ themes included suggestions for more radical solutions (e.g. flyovers, roundabout removal and road widening).

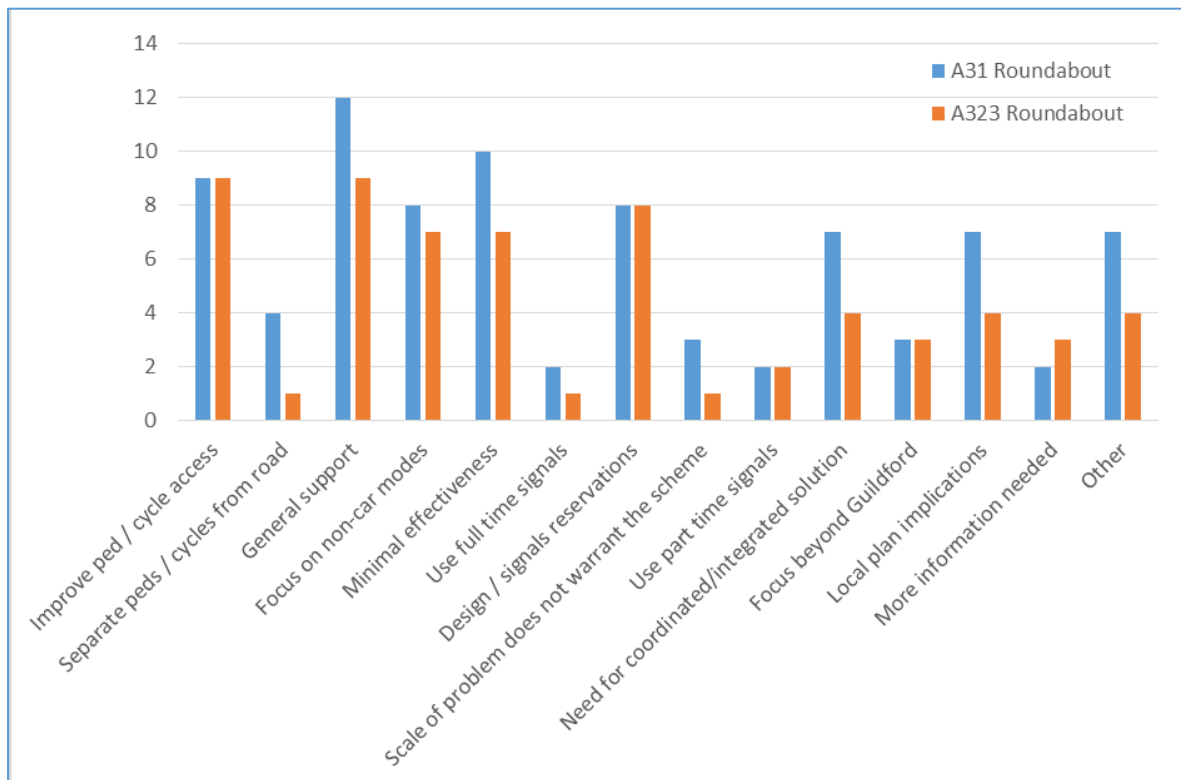

**Q8 – If you have any further comments you would like to provide on any of the four schemes please provide them here.**

95 free text responses were received to Q8 where responses were not directed towards a specific scheme.

A selection of comments that were included within responses to Q8 are provided below to give some examples of issues that were felt to be of importance by respondents. Given the wide range of responses it is not possible to group these into common themes, however all will be considered as appropriate for each of the projects.

Since moving to Guildford over 7 years ago I have always been amazed how public transport is so poor for a small town. Many towns do this very well. Without investing in good public transport and understanding the customer experience no one will ever get out of their cars.

It is very good that these traffic problems are being addressed. I regularly get stuck in a queue by car or bus from Guildford Park Road to the A281 or town centre bus station for up to 15 minutes.

Weak schemes. Will do little to help. Tinkering at the margin

More needs to be done to encourage people to use sustainable transport methods, principally walking and cycling.

As a member of the local Guildford Flood Action group we are very keen that the flood alleviation scheme goes ahead as soon as possible to prevent another flood event. However, more detail on this for the local community that aren't as involved as we are would be good. Most people don't know anything about it and it would be good to get some information out there.

None of these really address the most significant traffic problem around Guildford - which is the delays on the A3, which then leads to significant voluntary diversion of some traffic through the town centre, causing delays on Farnham Road, Millbrook, Woodbridge Road, centre gyratory etc.

Doesn't go far enough to help when tens of thousands of homes and double the number of cars are going to hit Guildford's already stretched roads especially city centre. Don't build the new homes, invest in the cinema area of the city centre to improve the quality of the social spaces.

Thanks to the Council representatives who took time to attend and give very helpful explanations.

You need to get people OFF the roads. There is nothing in here about pedestrians and cyclists. Forward thinking towns and cities are working hard to improve cycling. This looks like another piecemeal approach to 'doing something' rather than looking at things holistically. Don't focus on making it easier for cars to flow through. Focus on getting less cars coming through in the first place. Easy cycling, reliable public transport.

I am very supportive of the traffic management proposals and bus improvements, I would want to see more focus on buses so that they are a better alternative for car use (when walking not practical) for getting round the centre of town.

I'm intrigued by the idea that the proposed traffic management system will suggest alternative routes to avoid congestion. Not sure how this will work in the centre of Guildford, given the lack of alternative ways through the town.

## ITEM 11

### 'About You' section (Q9-Q14)

A number of questions relating to the respondent were asked to assist with analysis and future consultations.

#### Q9 – How did you hear about this consultation?

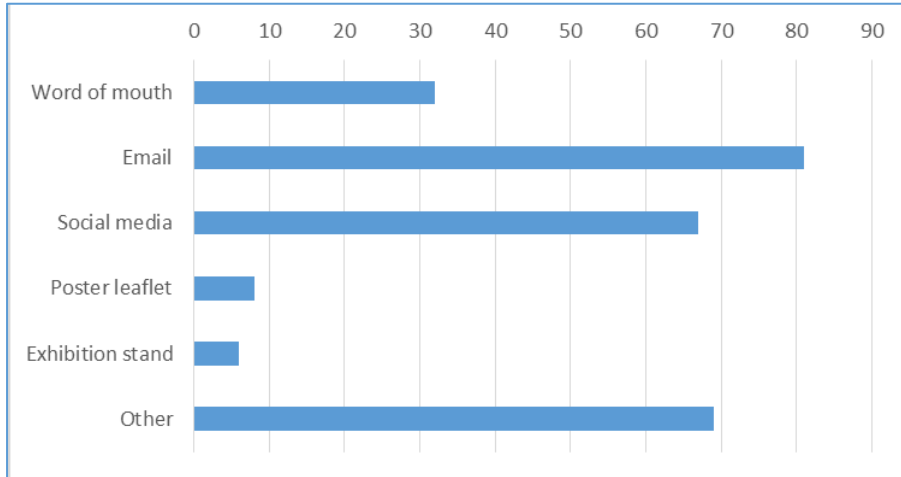

Respondents most commonly heard about the consultation via email and social media. 'Other' communication sources that were frequently mentioned included:

- SCC and GBC web pages
- University of Surrey
- School newsletters
- Local news outlets (e.g. Get Surrey)

#### Q10 – Gender identity

The responses to this question were:

Gender	Number	Percentage
Female	94	37%
Male	146	57%
Other	2	1%
Rather not say	13	5%

#### Q11 – What is your age group?

The responses to this question were:

Age group	Number	Percentage
17-24	7	3%
25-44	88	35%
45-64	99	39%
Over 64	43	17%
Rather not say	18	7%

**Q12 – Do you consider yourself to have a disability?**

18 respondents (7%) identified as having a disability with a further 15 respondents preferring not to say.

**Q13 – Please indicate if you are commenting as one of the following:**

The large majority of responses received via questionnaire were provided by respondents identifying as a local resident. Local businesses made up around 5% of the responses received via the questionnaire.

Category	Number	Percentage
A local resident	222	87%
A visitor	10	4%
A local business	14	5%
A community organisation	1	<1%
Other	8	3%

**Q14 – Postcode**

The postcode information collected through the questionnaire has been plotted in the map below to show the spread of responses and level of engagement across the borough. The map indicates two main clusters of responses, the largest of which is around Guildford itself with concentrations around the centre and to the north of the town. The second cluster is located in the vicinity of the A331 corridor, concentrated around Tongham, Ash and Aldershot.

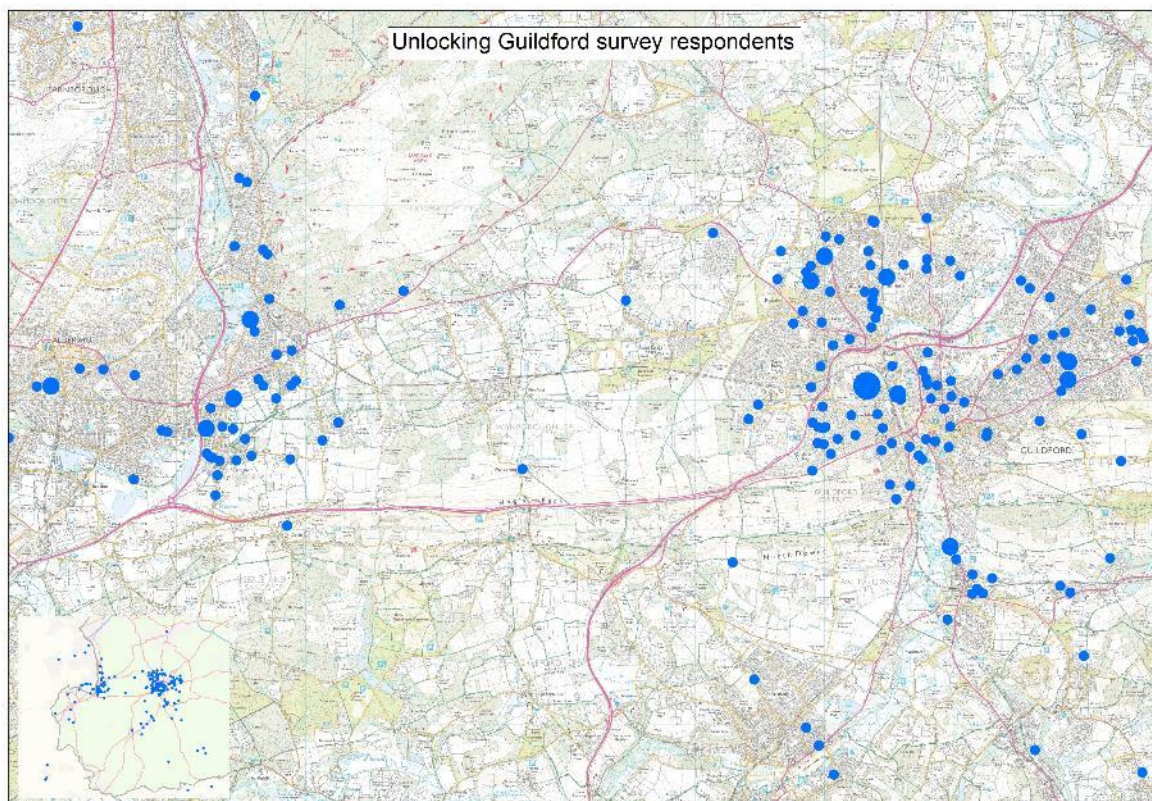

## ITEM 11

### Email/letter responses

During the consultation period we received written responses via email and letter from eight individuals and the following seven organisations:

- Guildford Access Group
- Guildford Vision Group
- Highways England
- Natural England
- Surrey Police
- Waverley Borough Council
- Guildford Bicycle User Group (G-BUG)

A number of written responses focussed in detail on the improvements to the bus network and provided suggestions on types of measures and areas of Guildford that were felt would be best targeted.

Other responses fed into the A331 junction improvements, with some requesting the addition of controlled pedestrian crossings and indicating that some junction arms would become more difficult to cross as a result of the improvements without their inclusion.

Many of written responses that were received included feedback that went beyond the scope of the individual schemes presented as part of the Unlocking Guildford package and used the opportunity to provide comments on other transport issues in the area. Therefore, as well as being used to inform the development of the schemes in the Unlocking Guildford package, the feedback may also prove useful for later reference in relation to developing any future strategic transport policy work around Guildford.

### **5. Conclusions**

Overall there has been a positive response to the schemes within the Unlocking Guildford package. There is general support for each of the proposals and a recognition of the problems which they seek to address. There was not a high level of negative responses to any of the projects in the package.

In addition to providing support for the business case, the comments received will be used to aid the development of each project. There are some key themes for the projects which were emerging, and whilst some are not necessarily in either SCC's or GBC's immediate control, we will continue to work with partners and relay the valuable information which will help us improve service provision in the borough.

Feedback received in the form of both written comments and verbal conversations at public exhibitions have highlighted an appetite for further strategic transport schemes to tackle other problems within the borough and a disappointment that more comprehensive or radical interventions, particularly within Guildford town centre and on the A3 are not yet proposed. However, the respondents are generally pleased that some of the issues are starting to be addressed.

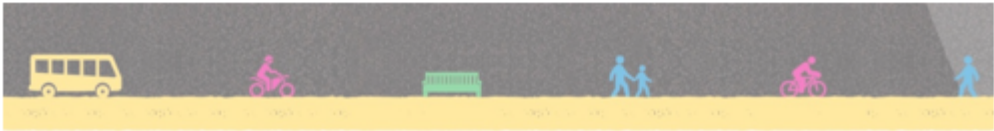

## Appendix A (Questionnaire)

Your views					
<b>(1) To what extent do you agree with the following schemes within the Unlocking Guildford package? (Please tick one per row)</b>					
	Strongly Agree	Agree	Neutral	Disagree	Strongly Disagree
1. Improving our bus network	<input type="checkbox"/>	<input type="checkbox"/>	<input type="checkbox"/>	<input type="checkbox"/>	<input type="checkbox"/>
2. A331 Blackwater Valley Relief Road junction improvements	<input type="checkbox"/>	<input type="checkbox"/>	<input type="checkbox"/>	<input type="checkbox"/>	<input type="checkbox"/>
3. Town centre approaches	<input type="checkbox"/>	<input type="checkbox"/>	<input type="checkbox"/>	<input type="checkbox"/>	<input type="checkbox"/>
4. Town centre flood alleviation	<input type="checkbox"/>	<input type="checkbox"/>	<input type="checkbox"/>	<input type="checkbox"/>	<input type="checkbox"/>
<b>(2) How often do you travel by bus around Guildford? (Please tick one)</b>					
Three times a week or more	Once or twice a week	Less than once a week but more than once a month	Once a month or less	Never	
<input type="checkbox"/>	<input type="checkbox"/>	<input type="checkbox"/>	<input type="checkbox"/>	<input type="checkbox"/>	
<b>(3) Would the proposed bus improvements make you likely to use the bus more often, or consider travelling by bus if you are not currently a bus user? (Please tick one)</b>					
Yes	<input type="checkbox"/>				
No	<input type="checkbox"/>				
<b>(4) If you feel there is something missing from the proposed bus improvements that would encourage more people to travel by bus around Guildford, please provide details below:</b>					
<hr/>					
<hr/>					
<hr/>					
<hr/>					
<b>(5) How often do you travel through either of the two junctions targeted in the A331 Blackwater Valley Relief Road junction improvements? (Please tick one)</b>					
Three times a week or more	Once or twice a week	Less than once a week but more than once a month	Once a month or less	Never	
<input type="checkbox"/>	<input type="checkbox"/>	<input type="checkbox"/>	<input type="checkbox"/>	<input type="checkbox"/>	
					

(6) To what extent to you feel that congestion is a problem that needs to be addressed at the following junctions? (Please tick one per row)

	Strongly Agree	Agree	Neutral	Disagree	Strongly Disagree	Don't Know
A31/A331 roundabout	<input type="checkbox"/>	<input type="checkbox"/>	<input type="checkbox"/>	<input type="checkbox"/>	<input type="checkbox"/>	<input type="checkbox"/>
A331/A323 roundabout	<input type="checkbox"/>	<input type="checkbox"/>	<input type="checkbox"/>	<input type="checkbox"/>	<input type="checkbox"/>	<input type="checkbox"/>

(7) Do you have any comments or suggestions regarding the proposals for either of the two roundabouts on the A331? If so, please give your views here:

---

---

---

---

(8) If you have any further comments you would like to provide on any of the four proposed schemes please provide them here:

---

---

---

---

---

---

---



### About you

It would help us analyse this questionnaire if you could let us know about you. Any information you provide will be treated in strictest confidence in accordance with the Data Protection Act (1998) and the Market Research Code of Conduct. It will not be passed to third parties or used for other purposes. Individual respondents will not be identifiable.

**(9) How did you hear about this consultation?**

Word of mouth     Email     Social media     Poster/leaflet     Exhibition stand     Other (please specify) \_\_\_\_\_

**(10) Gender identity:**

Male     Female     Other     Rather not say

**(11) What is your age group?**

Under 17     17–24     25–44     45–64     Over 64     Rather not say

**(12) Do you consider yourself to have a disability?**

Yes     No     Rather not say

**(13) Please indicate if you are commenting as one of the following (Please tick one):**

A local resident     A local business     Other   
 A visitor     A community organisation     Rather not say

**(14) To help us to analyse the results it would be helpful if you could provide your postcode (this information will not be used to identify you or your individual property):**

Postcode: \_\_\_\_\_

**Thank you for completing this questionnaire. Your input form part of our overall assessment of the schemes and help us to develop them further.**

All public consultation information on the project, including an electronic copy of this questionnaire, can be found on our website:

[www.surreycc.gov.uk/guildfordtransportschemes](http://www.surreycc.gov.uk/guildfordtransportschemes)

Paper questionnaires should be returned to: Surrey County Council Transport Policy, Room 420 County Hall, Penrhyn Road, Kingston, KT1 2DW by **Sunday 4 March 2018**

Email us: [majorschemes@surreycc.gov.uk](mailto:majorschemes@surreycc.gov.uk)



This page is intentionally left blank

## SURREY COUNTY COUNCIL

## LOCAL COMMITTEE (GUILDFORD)

DATE: 21 MARCH 2018

LEAD OFFICER: JOHN HILDER – AREA HIGHWAY MANAGER (SW)

SUBJECT: HIGHWAYS UPDATE

AREA(S) AFFECTED: ALL DIVISIONS IN GUILDFORD

**SUMMARY OF ISSUE:**

This report provides an update on the 2017/18 programme of highway improvement and maintenance works funded by this committee, an update on other centrally funded projects being promoted in the local area, as well as details of the budgets allocated to the committee in 2018/19 and recommendations on expenditure of the same.

**RECOMMENDATIONS:****The Local Committee (Guildford) is asked:**

- (i) To note the capital works being progressed during 2017/18
- (ii) To note the ongoing revenue works being carried out.
- (iii) To delegate to the Area Highway Manager, in consultation with the Chairman and Vice Chairman and Divisional Member, the ability to resolve any problems encountered to facilitate scheme delivery.
- (iv) To agree the recommendations made by the transportation task group for utilising the available highways budget for 2018/19 made in this report.

**REASONS FOR RECOMMENDATIONS:**

The committee is asked to agree the recommendations to enable early progression of works orders.

**1. INTRODUCTION AND BACKGROUND:**

- 1.1 Surrey County Council's Local Transport Plan (LTP) aims to improve the highway network for all users. In general terms it aims to reduce congestion, improve accessibility, reduce the frequency and severity of road casualties, improve the environment, and maintain the network so that it is safe for public use.
- 1.2 The Local Committee for Guildford has an annual delegated highways budget with which to implement measures that contribute towards the objectives set out in Surrey County Council's LTP, according to local priorities.

## **2. ANALYSIS:**

### **2017/18 Budget/Programme of Works**

#### Revenue Maintenance

- 2.1.1 £40,909 (the entire budget) was allocated for the provision of a vegetation gang through the year under the direction of the maintenance engineer, who was to liaise with members, town & parish councils to deploy this resource to best effect.

#### Capital Maintenance

- 2.1.2 £36,363 (the entire budget) was allocated as follows.
  - £24,000 towards completing the Gole Road safety scheme
  - £5,363 towards providing signs and lines
  - £7,000 towards completing the Boxgrove Lane safety scheme

### **2018/19 Budget/Proposed Programme of Works**

#### Available Highway Budget

- 2.1.3 At the full Council meeting of 6 February 2018 it was agreed to establish a new Member Local Highway Fund from 2018/19 of £7.5k per divisional member, rising to £10k in 2019/20 and £15k in 2020/21
- 2.1.4 Additionally the countywide devolved Committee revenue budget has increased from £450k in 2017/18 to £1.85m in 2018/19. It is proposed to rise to £2m in 2019/20 and £2.5m by 2020/21.
- 2.1.5 This is to be allocated equally across the 11 Committees equating to £168,182 of revenue monies per Committee.
- 2.1.6 The countywide devolved Capital will remain at £400k for 2018/19, and again this is to be shared equally between the 11 committees, equating to £36,363.
- 2.1.7 *In summary:-*

Budget	Amount
Capital maintenance	<b>£36,363</b>
Revenue maintenance	<b>£168,182</b>
Revenue Highway Fund (per divisional member)	<b>£7,500</b>

### Proposed Programme of Works

2.1.8 The transportation task group that reports to this committee met on 6th March 2018 to agree recommendations on how this budget should be utilised. They prioritised continuing with the community gang, which has proved a success in the current year, and completing a number of improvement schemes which had been deferred due to budget constraints in 2017/18.

2.1.9 The task group recommended that the schemes highlighted below are implemented in the coming year at a total forecast value of £143,000 of Committee funding.

### Capital

Road No	Road name & town	Type of work	Committee budget £	Alternative funding External/Member highways fund £	Funding source
N/A	Various locations	General signage & street furniture	9,500		
D4012	Burpham Lane, Guildford	Traffic calming measures	30,000		
A248	New Road, Chilworth	Crossing improvement	5,000		
D851	Fairlands, Guildford	Dropped kerbs	10,000		
D4012	Woodruff Avenue, Guildford	Bollards and waiting restrictions	10,000		
C93	North Street, Guildford	Pedestrian refuge & road table	40,000		
A247	The Street, West Clandon	Speed limit only	7,000		
D4009	Trodds Lane, Guildford	Speed limit	2,500	2,500	Cllr Ellwood
D4016	Wodeland Avenue, Guildford	Speed cushions	3,000	7,000	Cllr D Goodwin
A323	Aldershot Road, Worplesdon	Pedestrian refuge	2,500	25,000	Parish Council
A281	The Street, Shalford	Pedestrian refuge	25,000		
		<b>TOTAL</b>	<b>144,500</b>	<b>34,500</b>	

### Revenue

2.1.10 The task group recommended that the schemes highlighted below are implemented in the coming year at a total forecast value of £60,000

Road name & town	Type of work	Committee budget £
Hurtmore Road, Shackleford	Footway Resurfacing	5,000
Various	Vegetation Gang for 26 weeks	45,000
Various	White works	5,000
Various	Drainage Investigation	5,000
	<b>TOTAL</b>	<b>60,000</b>

### Other highway related matters

#### 2.3 Customer services

2.3.1 The total number of enquiries received in the calendar year 2017 is 112,538, an average of 9,363 per month, a decrease of approximately 18% on 2016. The improvements to the website reporting, proactive messaging and provision of information to customers have contributed to this.

2.3.2 All reports are categorised at the point of logging, either automatically through the website or by officers. Safety defects are directed to Kier with the remainder passed to the SCC local office for further investigation. Although enquiries have decreased overall there has been a change in the balance of reports. During 2016 the average split was 45% SCC and 55% Kier, for 2017 this has seen a shift to 53/47. This can be attributed to changes in the way enquiries are recorded and also the reduction in resource to carry out condition (non-safety) works. The volume of reports has increased demand on the area teams.

2.3.3 For Guildford specifically, 13,175 enquiries were received between January and December of which 7,086 were directed to the local area office for action, of these 96% have been resolved. This is in line with the Highways countywide average.

2.3.4 For 2017, 362 stage 1 complaints were received (a 22% reduction on 2016) of which 75 Stage 1 and 21 Stage 2 were for the South West area. For Guildford there were 31 stage 1 and six escalated to stage 2. The service was found to be at fault in one of the stage 2 complaints following independent investigation. We continue to work closely with the corporate customer relations team and have created corrective action plans for all outstanding actions. In addition any remedial action identified at stage 1 is now monitored more closely to ensure compliance and reduce escalation to stage 2. There were also three complaints directed to the LGO that were not upheld.



- 2.3.5 Recent surveys conducted with our Highways Customer Panel showed that 75% of those surveyed were either satisfied or very satisfied with the customer service they received.
- 2.3.6 The total number of enquiries received for the nine months between January and September 2017 is 90,788, an average of 10,088 per month. This a slight reduction in the average for the first six months of 2017 which was 10,880 per month and is in line with the seasonal trend where the summer months generate less enquiries.

## **2.4 Major schemes**

- 2.4.1 Surrey County Council is not actively promoting any major highway schemes within Guildford at present.

### **Tunsgate**

- 2.4.2 Members will recall that at its meeting of the 22 March 2017, approval was given for the Public Realm enhancements to the Tunsgate part of the town centre.
- 2.4.3 The scheme is being sponsored and funded by Guildford Borough Council and implemented by SCC through their contractor Kier.
- 2.4.4 Highway works commenced in September concentrating on the footway on the opposite side of the road to the development which is now largely completed. Works were suspended earlier in November in accordance with the Christmas embargo for Guildford town centre and recommenced in early January.
- 2.4.5 Since then works have been progressing up from the Tunsgate arch with setts being laid along the carriageway. The contractor has not always been able to work productively to facilitate the Queensbury development, which is now due to open on 12<sup>th</sup> March. The highway works are due to complete early August.

### **B3000 New Pond Road Rail Bridge**

- 2.4.6 Both Guildford and Waverley Local Members were advised at the December round of Committees that Network Rail's life expired bridge, on New Pond Road, Compton, close to the Guildford Crematorium, required rebuilding.
- 2.4.7 Members were reminded that discussions were had with the 2 local MPs at an early stage, who supported the opportunity to improve and widen any new structure over the railway, however the huge financial implications of any additional widening were beyond economic reach of the County Council at this time.
- 2.4.8 Network Rail (NR) will now replace the bridge like for like, however the New Pond Road will require a road closure during the main construction phase of the works.
- 2.4.9 SCC officers (Local Highways, Structures, & Streetworks) have met with NR, their Consultants, and contractors. The initial programme indicates that the current plan is to close the road around the times they have track possession,

## ITEM 12

which is currently shown to be programmed from Monday 23 April to Friday 13 July 2018.

2.4.10 A full diversion route will be provided throughout this time via Guildford town centre (A3100, A31, A3, B3000).

2.4.11 SCC Communication Team and Network Rails public relations team will be working to keep residents, drivers, and members fully updated. To this end and in addition to any letter drop that NR have been asked to carry out, a local public event was also held recently, where NR and SCC officers were in attendance, apprising local residents and businesses to the exact extent of the works and to attempt to mitigate any local issues that may arise. This event was held on Tuesday 20th February 2018 at Shalford Village Hall, Upper Hall between 16:00 and 19:00, and was very well attended.

2.4.12 As part of these works, the site team will be installing scaffolding, excavating and re-instating the carriageway. A temporary site compound will be set up adjacent to the bridge on the land owned by Honey Brothers the Arboricultural Equipment Specialist.

### Summary of scheduled work to be undertaken as follows:

Date	Time	Activity
Monday 23 April to Friday 13 July 2018	08:00 – 18:00	Full closure of New Pond Road (B3000) with diversions
Sunday 29 April to Monday 30 April 2018	01:15 - 04:00	Preparatory work; installation of temporary scaffold bridge for road utility diversion
Saturday 26 May to Tuesday 29 May 2018	00:55 – 04:55	Removal of old overbridge and replacement of new overbridge
Sunday 24 June 2018	00:55 – 10:40	Removal of the temporary utility cable scaffold bridge
Sunday 24 June to Friday 13 July 2018	08:00 – 18:00	Reinstate utilities, completion of road surfacing, road markings
Friday 13 July 2018	18:00	New Pond Road (B3000) re-opened

## 2.5 Centrally funded maintenance

2.5.1 Operation Horizon lists are included within the Cabinet Member report.

## 2.6 Passenger Transport

2.6.1 There was no update at the time of writing this report.

## 2.7 Other key information, strategy and policy development

2.7.1 There was no update at the time of writing this report.

**3. OPTIONS:**

- 3.1 Officers seek to implement the most cost effective measures which meet scheme objectives. Officers will revert to the Chairman, Vice Chairman and Divisional Member, or indeed the Committee as appropriate, whenever Preferred options need to be identified.

**4. CONSULTATIONS:**

- 4.1 None at this stage. Officers will consult the Chairman, Vice Chairman and Divisional Members as appropriate in the delivery of the programmes detailed above.

**5. FINANCIAL IMPLICATIONS:**

- 5.1 The financial implications of this paper are detailed in section 2 above.

**6. WIDER IMPLICATIONS:**

<b>Area assessed:</b>	<b>Direct Implications:</b>
Crime and Disorder	A well-managed highway network can contribute to reduction in crime and disorder as well as improve peoples' perception of crime.
Equality and Diversity	It is an objective of Surrey Highways to take account of the needs of all users of the public highway.
Localism (including community involvement and impact)	The Local Committee prioritises its expenditure according to local priorities.
Sustainability (including Climate Change and Carbon Emissions)	No significant implications arising from this report.
Corporate Parenting/Looked After Children	No significant implications arising from this report.
Safeguarding responsibilities for vulnerable children and adults	No significant implications arising from this report.
Public Health	No significant implications arising from this report.

**7. CONCLUSION AND RECOMMENDATIONS:**

- 7.1 This Financial Year's approved programmes are currently in the process of being delivered.

**8. WHAT HAPPENS NEXT:**

- 8.1 The Area Highway Manager will work with Divisional Members, the Chairman and Vice-Chairman to deliver this Financial Year's approved programme of works.
- 

**Contact Officer:** John Hilder  
SCC Area Highway Manager SW  
Tel 0300 200 1003

**Consulted:**  
As detailed within the report.

**Annexes:**  
None

**Background papers:**  
Local Committee (Guildford) December 2017 Highways Update.

SURREY COUNTY COUNCIL

LOCAL COMMITTEE (GUILDFORD)



SURREY

DATE: 21 MARCH 2018

LEAD MEMBER: COLIN KEMP, CABINET MEMBER FOR HIGHWAYS

SUBJECT: CABINET MEMBER FOR HIGHWAYS - UPDATE

AREA(S) AFFECTED: ALL

**SUMMARY OF ISSUE:**

Cabinet Member is attending the committee to improve communications and to provide information of works in the local area.

**RECOMMENDATIONS:**

The Local Committee (Guildford) is asked to comment on the information.

**REASONS FOR RECOMMENDATIONS:**

To update the committee on the highways works in the local area.

**1. INTRODUCTION AND BACKGROUND:**

- 1.1 Cabinet Member Colin Kemp attended this meeting in the autumn to improve communication with the committee and also to talk through the work he is doing with highways teams.
- 1.2 At the meeting in the autumn, it was agreed that the Cabinet Member would return in the Spring to provide an update on this work.

**2. ANALYSIS:**

- 2.1 As Highway Authority and Lead Local Flood Authority what we do and the powers we have are largely governed by statute. We are responsible for assets which include over 3,000 miles of road network, 1,800 bridges and structures and 3,262 miles of footway.
- 2.2 The Cabinet Member recognises that it is important to keep the Local Committees and Joint Committees informed. The programme summary (Annex 2) outlines all the highway work that is planned to be undertaken in the 2018/19 financial year (called operation Horizon). It will be updated every three months and is available on the following webpage – [www.surreycc.gov.uk/Horizon](http://www.surreycc.gov.uk/Horizon)

**3. OPTIONS:**

- 3.1 The committee can comment on and feedback views to the Cabinet Member for consideration.

**4. CONSULTATIONS:**

- 4.1 Officers from within the Environment and Infrastructure Directorate have inputted into this report, including Area Highways Managers.

**5. FINANCIAL IMPLICATIONS:**

- 5.1 All the works set out within the report are costed as part of the Council's budget for either 2017/18 or 2018/19 (as set out in the annex).

**6. WIDER IMPLICATIONS:**

Area assessed:	Direct Implications:
Crime and Disorder	No significant implications arising from this report.
Equality and Diversity	No significant implications arising from this report.
Localism (including community involvement and impact)	No significant implications arising from this report.
Sustainability (including Climate Change and Carbon Emissions)	No significant implications arising from this report.
Corporate Parenting/Looked After Children	No significant implications arising from this report.
Safeguarding responsibilities for vulnerable children and adults	No significant implications arising from this report.
Public Health	No significant implications arising from this report.

**7. CONCLUSION AND RECOMMENDATIONS:**

- 7.1 The committee is invited to comment and feedback to the Cabinet Member about the programme.

**8. WHAT HAPPENS NEXT:**

- 8.1 The Cabinet Member will consider the views of the committee.

**Contact Officer:** Cabinet Member for Highways Colin Kemp  
[colin.kemp@surreycc.gov.uk](mailto:colin.kemp@surreycc.gov.uk)

**Consulted:** As detailed within the report.

**Annexes:** Highways Programme Annual Summary 2018/19  
 Horizon 2 – Guildford 2017/18  
 Horizon 2 – Guildford 2018/19  
 Horizon 2 – Schemes for Consideration for Future Years

**Background papers:** None

## Introduction:

The Cabinet Member recognises that it is important to keep the Local Committees and Joint Committees informed. This programme summary outlines all the highway work that is planned to be undertaken in the 2018/19 financial year (called operation Horizon). It will be updated every three months and is available on the following webpage – [www.surreycc.gov.uk/Horizon](http://www.surreycc.gov.uk/Horizon)

Our purpose is to enable safe, reliable journeys and the growth of prosperous places, now and in the future. As Highway Authority and Lead Local Flood Authority what we do and the powers we have are largely governed by statute. We are responsible for assets which include over 3,000 miles of road network, 1,800 bridges and structures and 3,262 miles of footway.

## Our budget



From the **2018/19 central budgets for Guildford:**

**£2.512 million** has been budgeted for **resurfacing of roads**, and **£533k** for **pavement works**

**Since 2013/14 (the last 5 years) for Guildford:**

**The following has been invested centrally on the highway network in Guildford:**

**£18.962 million** on **resurfacing roads**  
**£480k** on Local Structural Repair (**LSR**)  
**£1.371million** on **pavements**  
 and **£3.236million** on **Structures**

Annex 1 provides an update on schemes undertaken in the 2017/18 financial year.  
 Annex 2 provides details on planned works in the 2018/19 financial year.  
 Annex 3 outlines works and schemes that we would like to complete in future years.

## ITEM 13

### **Grass cutting**

This year we are funding grass cutting to cover the area of 26.5million square-metres (county-wide) – that’s the area of 394 Wembley stadiums.

Guildford Borough Council have agreed to manage grass cutting in your Borough. It will be for the Borough Council to determine service levels but at a minimum they will be cutting the urban grass four times and the rural grass twice. Within Guildford there is about 710,000 square metres of urban highway grass and 590,000 square metres of rural highway grass. Areas classified as “urban” are normally verges in residential areas.

### **Defects**

In 2017 we repaired 37,702 dangerous defects, 4,182 of which were in Guildford.

There were 542 accident and emergency call outs in Guildford last year.

### **What happens to potholes?**

We regularly inspect the roads and pavements for potholes and other problems however we rely on the public to report problems to us in between these inspections.

### **Ways for the public to report**

🖨 Online at [www.surreycc.gov.uk](http://www.surreycc.gov.uk) (24 hours a day)

☎ 0300 200 1003 (local rate) 9am to 5pm, Monday to Friday

We prefer that reports are made online because this means we collect all the information we need including an accurate location of the problem. Residents can also track problems and see what has already been reported on the online map.

### **What happens after the report is made?**

One of our inspectors will visit the location within one week, look at the problem and decide what to do next:

- what type of repair needs to be made;
- when it needs to be made (we repair more risky defects in a shorter timescale); or
- determine if no repair is necessary (we will monitor instead)

Our inspector follows the highway safety manual. The manual takes into consideration lots of factors including where in the road the problem is. For example if the problem is on the pavement or in a cycle lane this is treated more seriously than if the problem was in the middle of the road.

More information about the highway safety manual is available at [www.surreycc.gov.uk/roadsafetystandards](http://www.surreycc.gov.uk/roadsafetystandards)



## What repair do we make?

We provide a list to our work team of all the defects that need repairing each day. Our work team must repair all of these risky defects by the end of the day in order to keep the network safe. This means the repair team may sometimes leave other non-urgent potholes nearby.

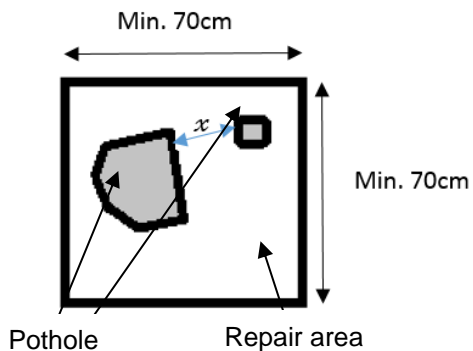

The work team may find other potholes nearby. These additional potholes may be repaired along with the pothole listed for repair, providing the patch size is not too big.

The distance " $x$ " is determined by the work team on site. They will consider:-

- the strength of the road to hold the repair,
- the amount of tarmac they have on them, and
- other engineering factors.



Before - three defects treated as one single defect



After

Not all potholes affect safety, and they will not normally be repaired, unless they are likely to become safety problem in the near future.



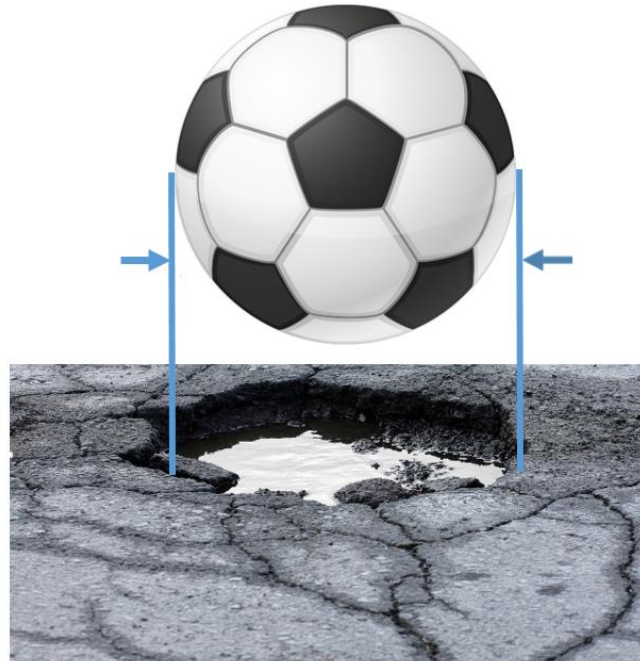

# ITEM 13

## What size is my pothole?

The descriptions used on the website refer to the width of the pothole (not depth).



## Summary of the classification of potholes

Highest risk Priority 1	Medium risk Priority 2	Low risk Priority 3	Priority 4 (May be unpleasing to the eye but not considered a safety issue)
What happens to this pothole?			
Make safe within 2 hours	Make safe or repair within 5 working days	Repair within 20 working days	We do not usually repair these potholes
Individual or multiple potholes with very high risk of interaction with vehicles or pedestrians and likely to result in serious or fatal consequence	Individual defect greater than 40mm in depth and 150mm in diameter (Cycle lanes 25mm depth and 75mm diameter)	Individual defect greater than 30mm in depth and 150mm in diameter (Cycle lanes 20mm depth and 75mm diameter).	Individual or multiple defects less than 30mm in depth or less than 40mm but unlikely to worsen (20mm in cycle lanes).
			

- Legend**
- Road Schemes
  - Pavement Schemes
  - Safety Barrier Schemes
  - Drainage Schemes
  - Structures Schemes
  - Embankment Schemes
  - Traffic Signal Schemes
  - LEP/Major Projects

Page 67



ITEM 13

This page is intentionally left blank

Surrey Highways

## **Horizon 2 2017-18**

Guildford – version 3.2, 15 February 2018



Horizon 2 is the name we are giving the Council's Asset Management Programme for the period 2017 to 2021.

## Horizon 2 – 2017/18 programme, GUILDFORD

### Horizon 2 ROADS programme

Road No.	Road / scheme name	Location	Limits	Length (metres)	Type of Work	Year	Surrey Highways ID	Scheme status
A323	Aldershot Road	Guildford	Southway to Rydes Hill Road	465	Road Surface Treatment	2017/18	3281	<b>Completed</b>
D266	Church Street / Browns Lane	Effingham	Entire length	621	Road Surface Treatment	2017/18	1332	<b>Completed</b>
A25	Dorking Road	Gomshall	Railway Bridge for 300 meters	374	Road Surface Treatment	2017/18	3295	<b>Completed</b>
D205	East Shalford Lane	Shalford	A281 The Street to D4015 Tilehouse Road	200	Road Surface Treatment	2017/18	3282	<b>Completed</b>

## Horizon 2 ROADS programme continued

Road No.	Road / scheme name	Location	Limits	Length (metres)	Type of Work	Year	Surrey Highways ID	Scheme status
B3012	Gole Road	Pirbright	Vapery Lane to Dawney Hill	945	Road Major Maintenance	2017/18	2638	<b>Deferred</b> The road is in better condition than we expected at this time, and the surface work undertaken in 2016 appears to have addressed safety concerns. We are continuing to monitor this road and it will remain on the list of roads to be considered over the next four years.
A31	Runfold Diversion	Guildford	A31 / A331 roundabout	240	Road Major Maintenance	2017/18	1079	<b>Completed</b>
C23	Sands Road	Seale	Littleworth Road to Brighton Lane	855	Road Major Maintenance	2017/18	426	<b>Completed</b>
D221	Sandy Lane	Albury	New Road to Pavillion	265	Road Surface Treatment	2017/18	2538	<b>Completed</b>
C20	Seale Lane	Farnham	Totford Lane to Shoelands Farm	285	Road surface treatment	2017/18	413	<b>Completed</b>
A25	Station Road	Gomshall	Goose Green to Railway Bridge	272	Road Surface Treatment	2017/18	3291	<b>Completed</b>
A25/A246	Epsom Road	West Clandon	A25/A247/A246 approaches and junction	565	Road Major Maintenance	2017/18	1081	<b>Completed</b>



Horizon 2 PAVEMENT programme								
Road No.	Road / scheme name	Location	Limits	Length (metres)	Type of Work	Year	Surrey Highways ID	Scheme status
D616	Church View	Ash	Ewins Close to Longacre	760	Pavement Slurry Seal	2017/18	149	<b>Completed</b>
D851	Envis Way	Guildford	Brock Drive to Louis Fields - both sides	630	Pavement Reconstruct	2017/18	1014	<b>Completed</b>
D4024	Grange Close	Guildford	Full length	90	Pavement Slurry Seal	2017/18	222	<b>Deferred</b> This type of work requires warmer temperatures to allow the slurry material to set. The scheme will therefore move to summer 2018.
D4000	Homestall	Guildford	Applegarth Avenue to Cabell Road	700	Pavement Slurry Seal	2017/18	216	<b>Deferred</b> This type of work requires warmer temperatures to allow the slurry material to set. The scheme will therefore move to summer 2018.
D54	Keens Lane	Guildford	Tangley Lane to Worplesdon Road - one side	40	Pavement Slurry Seal	2017/18	46	<b>Completed</b>

## Horizon 2 PAVEMENT programme continued

Road No.	Road / scheme name	Location	Limits	Length (metres)	Type of Work	Year	Surrey Highways ID	Scheme status
B367	Newark Lane	Ripley	Georgelands to High Street	900	Pavement Slurry Seal	2017/18	194	Completed
D4019	Old Court Road	Guildford	Full length	276	Pavement Slurry Seal	2017/18	212	Completed
D4021	Rydes Avenue	Guildford	Full length	312	Pavement Slurry Seal	2017/18	224	Completed
D620	Sandfields	Send	Full length	200	Pavement Slurry Seal	2017/18	197	Completed
C16	School Lane	Normandy	Pirbright Road to Wyke Primary School (entrance north of playing field) - west	150	Pavement Reconstruct	2017/18	1030	Completed

## Horizon 2 STRUCTURES programme

Road No.	Road / scheme name	Location	Limits	Length (metres)	Type of Work	Year	Surrey Highways ID	Scheme status
A331	Blackwater Valley Route	Ash	Canal Aquaduct Bridge - Waterproofing	N/A	Structures	2017/18	A331/14	<b>Deferred to 2018/19 and 2019/20 financial years</b> In order to assess the extent of waterproofing deterioration, the canal has to be drained down. This can only be done during the winter months when canal use is quieter. Investigation works will be carried out in between April 2018 and March 2019. Repair works will take place between April 2019 and March 2020.
A331	Blackwater Valley Route	Ash	A331 Aldershot Road Underpass South - Major Maintenance	N/A	Structures	2017/18	A331/4	<b>Deferred - Awaiting new date</b> Inspections were completed during September 2017. Our inspection did not identify any required work that would be a priority on this particular works list. Any work required may be carried out under a local enterprise partnership bid. This is a bid for funding and works may be carried out as part of a major scheme. Further details to be confirmed.

## Horizon 2 STRUCTURES programme continued

Road No.	Road / scheme name	Location	Limits	Length (metres)	Type of Work	Year	Surrey Highways ID	Scheme status
A331	Blackwater Valley Route	Ash	A331 Aldershot Road Underpass North - Major Maintenance	N/A	Structures	2017/18	A331/7	<b>Deferred - Awaiting new date</b> Inspections were completed during September 2017. Our inspection did not identify any required work that would be a priority on this particular works list. Any work required may be carried out under a local enterprise partnership bid. This is a bid for funding and works may be carried out as part of a major scheme. Further details to be confirmed.
A331	Blackwater Valley Route	Tongham	Tongham Moor Subway - Major Maintenance	N/A	Structures	2017/18	A331/1	<b>Deferred – Awaiting new date</b> Inspections were completed during September 2017. Our inspection did not identify any required work that would be a priority on this particular works list. Any work required may be carried out under a local enterprise partnership bid. This is a bid for funding and works may be carried out as part of a major scheme. Further details to be confirmed.
A248	Broadford Road	Peasmarsh	Broadford Railway (Disused) - Assessment	N/A	Structures	2017/18	A248/8	<b>Ongoing</b> Bridge assessment only. Further works may not be needed.

## Horizon 2 STRUCTURES programme continued

Road No.	Road / scheme name	Location	Limits	Length (metres)	Type of Work	Year	Surrey Highways ID	Scheme status
A31	Farnham Road	Guildford	Farnham Road Bridge - Feasibility / Design	N/A	Structures	2017/18	A31/2	<b>Deferred – awaiting new date</b> This is a Network Rail bridge. Network Rail have works programmed for December 2018
A31	Hogsback	Runfold	A331 I/C East - Major Maintenance	N/A	Structures	2017/18	A31/24	<b>Deferred – awaiting new date</b> Inspections were completed during September 2017. Our inspection did not identify any required work that would be a priority on this particular works list. Any work required may be carried out under a local enterprise partnership bid. This is a bid for funding and works may be carried out as part of a major scheme. Further details to be confirmed.
A31	Hogsback	Runfold	A331 I/C West - Major Maintenance	N/A	Structures	2017/18	A31/25	<b>Deferred – awaiting new date</b> Inspections were completed during September 2017. Our inspection did not identify any required work that would be a priority on this particular works list. Any work required may be carried out under a local enterprise partnership bid. This is a bid for funding and works may be carried out as part of a major scheme. Further details to be confirmed.

Horizon 2 STRUCTURES programme continued								
Road No.	Road / scheme name	Location	Limits	Length (metres)	Type of Work	Year	Surrey Highways ID	Scheme status
D203	Tilthams Corner Road	Peasmarsh	Unstead New Cut - Refurbishment	N/A	Structures	2017/18	D203/634	<p><b>Deferred</b></p> <p>Design of the scheme will take place in the 2018/19 financial year.</p> <p>We also aim to carry out construction work in 2018/19.</p>

ITEM 13

## Horizon 2 TRAFFIC SIGNALS programme

Road No.	Road / scheme name	Location	Limits	Length (metres)	Type of Work	Year	Surrey Highways ID	Scheme status
A25	Epsom Road	Merrow	Near Merrow Street	NA	Traffic Signals	2017/18	P726	<b>Deferred</b> - Having reviewed with Siemens the completion of recent traffic signals refurbishments, we have now reviewed the deliverability of what is a complex ongoing refurbishment programme and have taken the decision to defer these refurbishments until such time that both Surrey CC and Siemens Officers are confident the refurbishments can be satisfactorily completed whilst providing best value.
A246	Guildford Road	Effingham	Junction with Beech Avenue / The Street (Effingham Crossroads)	N/A	Traffic Signals	2017/18	J723	<b>Deferred</b> - Having reviewed with Siemens the completion of recent traffic signals refurbishments, we have now reviewed the deliverability of what is a complex ongoing refurbishment programme and have taken the decision to defer these refurbishments until such time that both Surrey CC and Siemens Officers are confident the refurbishments can be satisfactorily completed whilst providing best value.
A322	Onslow Street	Guildford	Junction with Woodbridge Road	N/A	Traffic Signals	2017/18	J763	<b>Completed</b>
A320	Woking Road	Guildford	Near Hazel Avenue	N/A	Traffic Signals	2017/18	P781	<b>Deferred</b> - Having reviewed with Siemens the completion of recent traffic signals refurbishments, we have now reviewed the deliverability of what is a complex ongoing refurbishment programme and have taken the decision to defer these refurbishments until such time that both Surrey CC and Siemens Officers are confident the refurbishments can be satisfactorily completed whilst providing best value.

## Horizon 2 EMBANKMENTS programme

Road No.	Road / scheme name	Location	Limits	Length (metres)	Type of Work	Year	Surrey Highways ID	Scheme status
D203	Trunley Heath Road	Shalford	Grid Ref:499782 146126 - Assessment / Feasibility report	N/A	Embankment	2017/18	N/A	<b>Completed</b>

## Horizon 2 DRAINAGE programme

Road No.	Road / scheme name	Location	Length (metres)	Type of Work	Year	Surrey Highways ID	Scheme status
A31	Hogs Back	Puttenham	N/A	Drainage	2017/18	Gui154	<b>Deferred – Awaiting new date</b> Previous works to resolve a wet spot have been partially successful. A re-assessment will take place. Any further works found will be prioritised to be included on a future works list.
A25	Station Road	Gomshall	N/A	Drainage	2017/18	Gui078	<b>Deferred</b> Deferred whilst private land agreements are put in place. Scheduled to start between April 2018 and March 2019



## Horizon 2 SAFETY BARRIERS programme

Road No.	Road / scheme name	Location	Limits	Length (metres)	Type of Work	Year	Surrey Highway s ID	Scheme status
D261	Colekitchen Lane	Gomshall	D261-001 Barrier Site - removal	N/A	Safety Barrier	2017/18	D261-001	<b>Completed</b>
D222	Pursers Lane	Shere	D222-001 Barrier Site - Crash barrier Works	N/A	Safety Barrier	2017/18	D222-001	<b>Scheduled</b> Works expected to start on 27 March 2018
B2039	Ockham Road North	Ockham	B2039-001 Barrier Site - removal	N/A	Safety Barrier	2017/18	B2039-001	<b>Completed</b>
A3100	Old Portsmouth Road	Peasmarsh	A3100-007 Crash barrier Works	N/A	Safety Barrier	2017/18	A3100-007	<b>Scheduled to start 12 March 2018</b> Risk assessments have shown that safety barriers are no longer required at this location so these will be removed. Works expected to start on 22 February 2018

## Safety Defect Resurfacing &amp; Patching (Funded by Department for Transport grant) January – March 2018

Road No.	Road / scheme name	Location	Limits	Type of Work	Year	Scheme status
D4012	Coltsfoot Drive	Burpham	From junction of Woodruff Avenue to no 6 Coltsfoot Drive	Carriageway surfacing works	2018	<b>Completed</b>
D4002	The Crescent	Guildford	From Aldershot Road to 1 The Crescent	Carriageway surfacing works	2018	<b>Completed</b>
D622	New Road	Gomshall	Various patches along New Road	Carriageway patching works	2018	<b>Completed</b>
D4015	Pewley Hill	Guildford	From 13-35 Pewley Hill	Carriageway surfacing works	2018	<b>Completed</b>
D611	Rickford Hill	Worplesdon	Full length	Carriageway surfacing works	2018	<b>Completed</b>
D4023	Stoughton Road	Guildford	Surfacing the crossroads area and section of Stoughton Road leading from the crossroads towards the cemetery.	Carriageway surfacing works	2018	<b>Scheduled</b> Scheduled to take place on 9 April

## Horizon 2 MAJOR TRANSPORT SCHEMES programme

Scheme name	Location	Other information
Guildford Sustainable Transport Package (STP) Page 83	Millbrook Car Park	<p><b>Currently taking place. Scheduled to finish in February 2018.</b></p> <p>The existing junction arrangement at Millbrook Car Park currently only allows traffic that exits the car park to turn left and enter the gyratory rather than turn right and travel southbound, putting additional pressure on town centre traffic. Currently, visitors who travel from the south of Guildford may also be discouraged from using the car park because of the difficulty in returning southbound after leaving. The scheme will involve reconfiguring the junction to enable traffic to turn right when exiting the car park, therefore easing the pressure on the gyratory and making the car park more attractive to potential users.</p>
	Woodbridge Road (Phase 2 of A25 cycle corridor) (near Wickes)	<p>The existing off-road shared-use pedestrian and cycle facility along the A25 was improved as part of the Local Sustainable Transport Fund in 2014/15, however there were a number areas along the route that could not be upgraded to a desirable standard at the time. As such, there are sections of the route that are incomplete and act as 'gaps' in the network where cyclists must dismount or join the road. As part of the Guildford STP these gaps will be filled in, extending or improving the existing shared-use facility in the following locations along the A25:</p> <ul style="list-style-type: none"> <li>• South side of the A25 Middleton Road between Middleton Industrial Estate Road and Surrey Way (<b>completed Spring 2017</b>)</li> <li>• Further works will be carried out from April 2018.</li> </ul>

This page is intentionally left blank

Surrey Highways

## Horizon 2 2018-19

Guildford – version 1.0, 17 January 2018

Horizon 2 is the name we are giving the Council's Asset Management Programme for the period 2017 to 2021.

## Horizon 2 – 2018/19 programme, GUILDFORD

### Horizon 2 ROADS programme

Road No.	Road name	Location	Limits	Length (metres)	Type of Work	Year	Surrey Highways ID	Other information
D44	Bisley Camp Road	Pirbright	Connaught Road to Brunswick Road	310	Major Maintenance	2018/19	CW 2500	
A248	Dorking Road	St Martha's	Blacksmith Lane to Mill Lane	1500	Major Maintenance	2018/19	CW 93	
A31	Farnham Road	Guildford	Bridge Street to Denzil Road	290	Major Maintenance	2018/19	CW2621	
B3000	Puttenham Heath Road	Compton	A3 (northbound) Roundabout to The Street	1500	Major Maintenance	2018/19	CW 342	
D194	New Road	Albury	A248 Sherbourne to Heath Lane	1260	Micro Asphalt	2018/19	CW2536	

## Horizon 2 ROADS programme continued

Road No.	Road name	Location	Limits	Length (metres)	Type of Work	Year	Surrey Highways ID	Other information
D258	Shere Road	West Horsley	Combe Lane to Pebble Hill	1140	Micro Asphalt	2018/19	CW2565	
D246	The Drift	East Horsley	Forest Road to Ockham Road North	1240	Micro Asphalt	2018/19	CW639	
C14	Clay Lane	Jacobswell	Queenhythe Road to Burpham Court Bridge (west)	600	Surface treatment	2018/19	CW3513	
D248	Green Lane	Ockham	Long Reach to Ockham Road North	751	Surface Dressing	2018/19	CW2569	
C37	Guildford Lane	Albury	Chilworth Road to White Lane	1423	Surface Dressing	2018/19	CW2641	
C46	Hound House Road	Shere	Hook Lane to Hound House Farm	2136	Surface Dressing	2018/19	CW 3317	
D237	Kiln Lane	Ripley	Portsmouth Road to End	437	Surface Dressing	2018/19	CW2561	



## Horizon 2 ROADS programme continued

Road No.	Road name	Location	Limits	Length (metres)	Type of Work	Year	Surrey Highways ID	Other information
C45	Staple Lane	East Clandon	Combe Lane for 400 meters North	415	Surface Dressing	2018/19	CW452	
C93	North Street	Guildford	High Street to Commercial Road	450	Major Maintenance	2018/19	CW3517	

## Horizon 2 PAVEMENT programme

Road No.	Road name	Location	Limits	Length (metres)	Type of Work	Year	Surrey Highways ID	Other information
C15	Broad Street	Guildford	Aldershot Road to Pinks Hill (both sides)	1850	Footway Slurry	2018/19	FW640	
D851	Fairlands Avenue	Fairlands	Brocks Drive to Kilns Meadow (both sides)	395	Footway Recon	2018/19	FW1028	

## Horizon 2 PAVEMENT programme continued

Road No.	Road name	Location	Limits	Length (metres)	Type of Work	Year	Surrey Highways ID	Other information
D60	Glaziers Lane	Normandy	Guildford Road to Flexford Road (both sides)	1800	Footway Recon	2018/19	FW19	
D4024	Grange Close	Guildford	Full length (both sides)	90	Footway Slurry	2018/19	FW222	Carried over from 2017/18 works list.
D4000	Homestall	Guildford	Applegarth Avenue to Cabell Road (both sides)	700	Footway Slurry	2018/19	FW216	Carried over from 2017/18 works list.
C15	Oak Hill	Wood Street Village	Oak Hill Properties (No. 88) to Shop/Post Office (northern side)	120	Footway Recon	2018/19	FW1027	
C20	Seale Lane	Seale, Puttenham	The Street to Munday's Boro Road (both sides)	240	Footway Slurry	2018/19	FW134	

### Horizon 2 STRUCTURES programme

Road No.	Road name	Location	Limits	Length (metres)	Type of Work	Year	Surrey Highways ID	Other information
	Farnham Road	Farnham Road Bridge			Bridge strengthening	2018/19		Network rail bridge

### Horizon 2 TRAFFIC SIGNALS programme

Page 91

Road No.	Road name	Location	Limits	Length (metres)	Type of Work	Year	Surrey Highways ID	Other information
A3100	Clay Lane	Burpham	Near Bowers Farm Drive	N/A	Traffic signal refurbishment	2018/19	P709	
A234 / B3405	Dawney Hill	Pirbright	Junction with School Lane	N/A	Traffic signal refurbishment	2018/19	J707	
A25	Epsom Road	Guildford	Near High Path Road	N/A	Traffic signal refurbishment	2018/19	P711	

## Horizon 2 TRAFFIC SIGNALS programme continued

Road No.	Road name	Location	Limits	Length (metres)	Type of Work	Year	Surrey Highways ID	Other information
A246 / C43	Guildford Road	Effingham	Junction with Beech Avenue / The Street (Effingham Crossroads)	N/A	Traffic signal refurbishment	2018/19	J723	<b>Carried over from 2017/18 works list</b>
A3100	London Road	Burpham	Near Kingpost Parade	N/A	Traffic signal refurbishment	2018/19	P759	
D90	Lower Eashing Road	Guildford	Near The Drive (Eashing Bridge – River Wey)	N/A	Traffic signal refurbishment	2018/19	J790	
A281 / A322	Millbrook	Guildford	Junction with Onslow Street	N/A	Traffic signal refurbishment	2018/19	J758	
A281	The Street	Shalford	Near Kings Road	N/A	Traffic signal refurbishment	2018/19	P730	
C119	The Street	Tongham	Near Poyle Road	N/A	Traffic signal refurbishment	2018/19	P704	
D4023 / D4022	Stoughton Road	Guildford	Junction with Manor Road / Grange Road / New Cross Road	N/A	Traffic signal refurbishment	2018/19	J745	

## Horizon 2 TRAFFIC SIGNALS programme continued

Road No.	Road name	Location	Limits	Length (metres)	Type of Work	Year	Surrey Highways ID	Other information
A320 / D4027	Woking Road	Burpham	Junction with Moorfield Road	N/A	Traffic signal refurbishment	2018/19	J710	
A322 / A323 / D4022	Worplesdon Road	Guildford	Junction with Aldershot Road	N/A	Traffic signal refurbishment	2018/19	J746	
A322	Worplesdon Road	Guildford	Near Barrack Road	N/A	Traffic signal refurbishment	2018/19	P744	
A322 / D4023 / D4020	Worplesdon Road	Guildford	Junction with Stoughton Road and Shepherds Lane	N/A	Traffic signal refurbishment	2018/19	J784	

Horizon 2 DRAINAGE programme								
Road No.	Road name	Location	Limits	Length (metres)	Type of Work	Year	Surrey Highways ID	Other information
A25	Station Road	Gomshall		N/A	Drainage repairs	2018/19	Gui078	
D4040	Wellesley Close	Ash Vale		N/A	Installation of soakaways to prevent flooding from sewer	2018/19	Gui162	

Horizon 2 EMBANKMENTS programme
No schemes currently prioritised

Horizon 2 SAFETY BARRIERS programme
No schemes currently prioritised

## Horizon 2 MAJOR TRANSPORT SCHEMES / SUSTAINABLE TRANSPORT PACKAGE / NETWORK RESILIENCE programme cont.

### Horizon 2 MAJOR TRANSPORT SCHEMES / SUSTAINABLE TRANSPORT PACKAGE / NETWORK RESILIENCE programme

Scheme name	Location	Other information
Guildford Sustainable Transport Package  Page 95	Walnut Tree Close	<p><b>Estimated to start between April 2018 and March 2019</b></p> <p>The proposals for Walnut Tree Close aim to reduce the amount of traffic using the road, particularly vehicles that use the road as a through-route between the A25 and the gyratory. To achieve this aim we are proposing two trial measures: a point-closure or a one-way traffic restriction on Walnut Tree Close.</p> <p>By doing this we hope to:</p> <ul style="list-style-type: none"> <li>• Reduce peak-hour queuing at both ends of Walnut Tree Close</li> <li>• Improve safety for all road users</li> <li>• Reduce the conflict between traffic exiting Walnut Tree Close and the gyratory</li> <li>• Create a more pleasant environment along the road to encourage more walking and cycling</li> </ul> <p>(This phase is subject to matters regarding land being agreed).</p>
	Walnut Bridge	<p><b>Estimated to start between April 2018 and March 2019</b></p> <p>The existing bridge over the River Wey will be replaced with a new and modern 'cable-stay' bridge designed for non-motorised users, linking Guildford Rail Station to the Bedford Wharf area. The scheme is being delivered by Guildford Borough Council. The location and alignment of the existing bridge means that visitors to Guildford who are less familiar with area are often unaware of it, whilst the current width requires cyclists to dismount when travelling across it.</p> <p>Access to the new bridge will no longer be hidden by the surrounding buildings on Walnut Tree Close which should encourage greater use by those travelling between the rail station and town centre. The new bridge will also be considerably wider, providing an easier route for cyclists without the need to dismount.</p>

Scheme name	Location	Other information
Guildford Sustainable Transport Package (STP) (continued)	Guildford College Link +	<p><b>Estimated to start between February and April 2019</b></p> <p>The link will use residential roads to provide a quiet and pleasant route for pedestrians and cyclists, connecting the new Walnut Bridge and the Bedford Wharf area to Guildford College. The scheme will include the provision of directional signs, new controlled crossings and the provision of off-road cycle facilities.</p>
	Millbrook Car Park	<p><b>Currently taking place. Estimated to finish in February 2018.</b></p> <p>The existing junction arrangement at Millbrook Car Park currently only allows traffic that exits the car park to turn left and enter the gyratory rather than turn right and travel southbound, putting additional pressure on town centre traffic. Currently, visitors who travel from the south of Guildford may also be discouraged from using the car park because of the difficulty in returning southbound after leaving. The scheme will involve reconfiguring the junction to enable traffic to turn right when exiting the car park, therefore easing the pressure on the gyratory and making the car park more attractive to potential users.</p>
	Woodbridge Road (Phase 2 of A25 cycle corridor) (near Wickes)	<p>The existing off-road shared-use pedestrian and cycle facility along the A25 was improved as part of the Local Sustainable Transport Fund in 2014/15, however there were a number areas along the route that could not be upgraded to a desirable standard at the time. As such, there are sections of the route that are incomplete and act as ‘gaps’ in the network where cyclists must dismount or join the road. As part of the Guildford STP these gaps will be filled in, extending or improving the existing shared-use facility in the following locations along the A25:</p> <ul style="list-style-type: none"> <li>• South side of the A25 Middleton Road between Middleton Industrial Estate Road and Surrey Way <b>(completed Spring 2017)</b></li> <li>• South side of the A25 Woodbridge Road between the A322 and Woodbridge Meadows <b>(Estimated to start between April 2018 and September 2018)</b></li> <li>• North side of the A25 Ladymead outside the Ladymead Retail Centre. <b>(start date to be confirmed) Estimated to start before March 2019.</b></li> <li>• South side of the A25 Parkway between Stoke Crossroads and Boxgrove Roundabout <b>(start date to be confirmed) Expected to start before March 2019.</b></li> </ul>

ITEM 13

Page 96



## Horizon 2 MAJOR TRANSPORT SCHEMES / SUSTAINABLE TRANSPORT PACKAGE / NETWORK RESILIENCE programme continued

Scheme name	Location	Other information
Guildford Sustainable Transport Package (continued)	A25 Cycle Corridor Phase 3 (Europa Retail Park)	<b>Approximate start date between March and April 2019</b>
	A25 Cycle Corridor (Parkway) Phase 4.	<b>Approximate start date between March and April 2018.</b>
	A25 /A320 Stoke Crossroads Improvements	<p><b>Approximate start date between July and September 2018.</b></p> <p>The junction of the A25 and A320 (Stoke Crossroads) is located along a popular route into the town centre from Stoughton, Slyfield and other areas north of Guildford. However, due to its links to the A3, Stoke Crossroads is a particularly busy junction for vehicular traffic and a difficult junction to cross for non-motorised users. Only two of the arms of the junction currently have controlled crossing facilities at surface level, and whilst the western arm has a pedestrian bridge the northern arm has no crossing facilities at all.</p> <p>The proposed improvements will provide improved crossing facilities across the junction for pedestrians and cyclists. It will also fill another gap in the A25 cycle network by widening the pathways on each of the corners of the junction to create a shared-use pedestrian and cycle facility. The traffic signals may also include the provision of intelligent services that prioritises late-running buses. Scheme will be carried out in partnership with Highways England.</p>

## Horizon 2 MAJOR TRANSPORT SCHEMES / SUSTAINABLE TRANSPORT PACKAGE / NETWORK RESILIENCE programme continued

ITEM 13

Scheme name	Location	Other information
<p>Guildford Sustainable Transport Package (continued)</p> <p><i>(Note: Delivery of all schemes is subject to the positive resolution of Land Issues, Road Safety Audits, Road Space, funding restrictions &amp; resources where relevant.)</i></p>	<p>A3100 London Road cycle facilities and improvements</p>	<p><b>Estimated to start between December 2018 and February 2019.</b></p> <p>The section of London Road between the Boxgrove Roundabout and London Road Rail Station currently has an on-road advisory cycle lane, however the cycle lane is intermittent and stops in some areas, particularly outside Stoke Park.</p> <p>The route will be improved to provide a continuous cycle facility along this section of London Road. Crossing facilities will also be improved along London Road for pedestrians whilst the facilities at a number of the bus stops will be upgraded.</p>

## Surrey Highways

# Horizon 2 Schemes for consideration for future years

## Guildford

Please note this is a provisional list. We cannot guarantee that any scheme on this list will be carried out.

1. This is a list of works being considered for future years
2. This list will change as condition survey information is received

## Horizon 2 – Schemes for consideration for future years - Guildford

### Horizon 2 ROADS Schemes for consideration for future years

Road No.	Road / scheme name	Location	Limits	Length (metres)	Type of Work	Surrey Highways ID	Other information
B380	Ash Road	Ash	Aldershot Road To Guildford Road	1497	Road Major Maintenance	374	
A323	Ash Street	Ash	Star Lane to Entrance of Memorial School	241	Road Major Maintenance	286	
D220	Blackheath Lane	Albury	Church Lane To End (Excluding private road)	1470	Road Major Maintenance	616	
A248	Chantry Lane	Shere	Upper Street to end of the road	340	Road Major Maintenance	620	
D225	Chantry View Road	Guildford	Shalford Road to end of the road	745	Road Major Maintenance	913	

3. This is a list of works being considered for future years
4. This list will change as condition survey information is received
5. This list is not in priority order

1. This is a list of works being considered for future years
2. This list will change as condition survey information is received

### Horizon 2 ROADS Schemes for consideration for future years - continued

Road No.	Road / scheme name	Location	Limits	Length (metres)	Type of Work	Surrey Highways ID	Other information
A248	Egerton Road	Guildford	Ashenden Road (Tesco) Roundabout	200	Road Major Maintenance	3344	
X281	Guildford Park Road	Guildford	Farnham Road To Ridgemount	390	Road Major Maintenance	3085	
A31	Horsham Road	Holmbury St. Mary	Felbury House To Felday Glade	600	Road Major Maintenance	2633	
B2126	Horsham Road	Shalford	Broadford Road To Stone Bridge (Just Beyond Somerswey)	516	Road Major Maintenance	1008	
A281	Horsham Road	Shalford	52 meters north of and including Kings Road roundabout to Conford Drive	448	Road Major Maintenance	178	
A281	Ladymead	Guildford	Woodbridge Road To Stoke Road (Inc Junctions)	554	Road Major Maintenance	160	

Page 101

ITEM 13

3. This is a list of works being considered for future years
4. This list will change as condition survey information is received
5. This list is not in priority order

1. This is a list of works being considered for future years
2. This list will change as condition survey information is received

ITEM 13

### Horizon 2 ROADS Schemes for consideration for future years - continued

Page 102

Road No.	Road / scheme name	Location	Limits	Length (metres)	Type of Work	Surrey Highways ID	Other information
D75	Lawn Road	Guildford	Entire length	85	Road Major Maintenance	286	
A323	Lime Grove	West Clandon	Clandon Road To Woodstock	180	Road Major Maintenance	2575	
D351	Madrid Road	Guildford	Ridgemount to Old Palace Road	240	Road Major Maintenance	3086	
A281	North Street	Guildford		500	Road Major Maintenance		
	New Pond Road	Peasmars h	Old Portsmouth Road To Church Access	590	Road Major Maintenance	2637	
A322	Overbrook / School Lane	West Horsley	Entire Length	240	Road Major Maintenance	1068	

3. This is a list of works being considered for future years
4. This list will change as condition survey information is received
5. This list is not in priority order

1. This is a list of works being considered for future years
2. This list will change as condition survey information is received

### Horizon 2 ROADS Schemes for consideration for future years - continued

Road No.	Road / scheme name	Location	Limits	Length (metres)	Type of Work	Surrey Highways ID	Other information
A281	Radnor Lane	Shere	Entire Length	517	Road Major Maintenance	668	
B3405	School Lane	Pirbright	A324 To West Heath	512	Road Major Maintenance	360	
C20	Send Barns Lane	Send	London Road To Woodhill	550	Road Major Maintenance	55	
D4020	Station Road	Shalford	Kings Road To Kings Road	380	Road Major Maintenance	2526	
C24	Tanger Road	Guildford		500	Road Major Maintenance		
A320	Woking Road	Guildford	Old Farm Road To Bellfields Road	440	Road Major Maintenance	2517	

Page 103

ITEM 13

3. This is a list of works being considered for future years
4. This list will change as condition survey information is received
5. This list is not in priority order

1. This is a list of works being considered for future years
2. This list will change as condition survey information is received

### Horizon 2 ROADS Schemes for consideration for future years - continued

Page 104

Road No.	Road / scheme name	Location	Limits	Length (metres)	Type of Work	Surrey Highways ID	Other information
D4025	Woking Road	Guildford	Whitemore Road To Old Farm Road	400	Road Major Maintenance	2516	
A322 / D4023	Horsham Road	Shalford	Broadford Road To Stone Bridge (Just Beyond Somerswey)	516	Road Major Maintenance	1008	
A281	Epsom Road	East Clandon	School Lane to Hatchlands ent (250m east of)	1675	Road Major Maintenance	51	
A246	Egerton Road	Guildford	Ashenden Road (Tesco) Roundabout	200	Road Major Maintenance	3344	
C146	Westfield Road	Guildford	Moorfield Road To End	727	Road Major Maintenance	936	
C43	Beech Avenue	Effingham	343 metres South of High Barn Road To St. Teresa's School Entrance	1293	Road Surface Treatment		

3. This is a list of works being considered for future years
4. This list will change as condition survey information is received
5. This list is not in priority order



1. This is a list of works being considered for future years
2. This list will change as condition survey information is received

### Horizon 2 ROADS Schemes for consideration for future years - continued

Road No.	Road / scheme name	Location	Limits	Length (metres)	Type of Work	Surrey Highways ID	Other information
D4000	Portsmouth Road	Ripley	Hurst Farm Entrance To Burntcommon Lane	1500	Road Surface Treatment		
A247	Shepherds Lane	Westborough	Worplesdon Road To Rydes Hill Road	460	Road Surface Treatment	925	

Page 105

3. This is a list of works being considered for future years
4. This list will change as condition survey information is received
5. This list is not in priority order

1. This is a list of works being considered for future years
2. This list will change as condition survey information is received

ITEM 13

### Horizon 2 PAVEMENTS Schemes for consideration for future years

Page 106

Road No.	Road / scheme name	Location	Limits	Length (metres)	Type of Work	Surrey Highways ID	Other information
A25	Pond Meadow	Guildford	Southway To Broomfield - Both Sides	860	Pavement Reconstruction	217	
B3000	Puttenham Hill	Puttenham	Hogs Back To The Heath - East	590	Pavement Reconstruction	632	
C44	School Lane	Pirbright	Dawney Hill To Grange Road - Both Sides	1300	Pavement Reconstruction	199	
A322	Woodruff Avenue	Guildford	London Road Roundabout To Charlock Way- Both Sides	520	Pavement Reconstruction	684	
A320	Stonecrop Road	Guildford	Full Length	92	Pavement Slurry Seal	7	
D4036	Stoughton Road	Stoughton	Worplesdon Road To Woking Road	1810	Pavement Slurry Seal	139	

3. This is a list of works being considered for future years
4. This list will change as condition survey information is received
5. This list is not in priority order

1. This is a list of works being considered for future years
2. This list will change as condition survey information is received

Horizon 2 PAVEMENTS Schemes for consideration for future years - continued							
Road No.	Road / scheme name	Location	Limits	Length (metres)	Type of Work	Surrey Highways ID	Other information
D4040	Woking Road	Guildford	Full Length	800	Pavement Slurry Seal	144	

Page 107

Horizon 2 STRUCTURES Schemes for consideration for future years							
Road No.	Road / scheme name	Location	Limits	Length (metres)	Type of Work	Surrey Highways ID	Other information
A323	Aldershot Road	Worplesdon	Clasford Bridge - Construction	N/A	Structures	A323/1	
D46	Church Lane	Pirbright	Church Lane Bridge - Construction	N/A	Structures	D46/2118	
A3100	Cobbett Hill Road	Worplesdon	Clasford Bridge - Feasibility / Design	N/A	Structures	D58/607	

ITEM 13

3. This is a list of works being considered for future years
4. This list will change as condition survey information is received
5. This list is not in priority order

1. This is a list of works being considered for future years
2. This list will change as condition survey information is received

ITEM 13

### Horizon 2 STRUCTURES Schemes for consideration for future years - continued

Page 108

Road No.	Road / scheme name	Location	Limits	Length (metres)	Type of Work	Surrey Highways ID	Other information
D58	Cobbett Hill Road	Worplesdon	Clasford Bridge - Construction	N/A	Structures	D58/607	
D851	Farnham Road	Guildford	Farnham Road Bridge - Construction	N/A	Structures	A31/2	
D60	Glaziers Lane	Normandy	Glaziers Lane (Station Road) - Construction	N/A	Structures	D60/613	
D898	Heathvale Bridge Road	Ash Vale	Heathvale Bridge - Construction	N/A	Structures	D898/2242	
D75	Lakeside Road	Ash	Government Road - Construction	N/A	Structures	D75/1781	
C24	Suffield Lane	Puttenham	Cutt Mill Culvert - Construction	N/A	Structures	C24/2225	

3. This is a list of works being considered for future years
4. This list will change as condition survey information is received
5. This list is not in priority order

1. This is a list of works being considered for future years
2. This list will change as condition survey information is received

### Horizon 2 DRAINAGE Schemes for consideration for future years

Road No.	Road / scheme name	Location	Limits	Length (metres)	Type of Work	Surrey Highways ID	Other information
D220	Blackwater Valley Road	Tongham	Between junctions with Ash Road and Aldershot Road	N/A	Drainage	Gui001	
D275	Ranmore Common Road	Dogkenne I Green	Crocknorth Road / White Down Lane crossroads	N/A	Drainage	Gui009	
D4007	The Street	Shalford	Junction with East Shalford Lane - Investigation. Improve Highway Drainage To Discharge To River During Rainfall With Stormwater Storage	N/A	Drainage	Gui008	
D203	Wellesley Close	Ash Vale	All of Wellesley Close	N/A	Drainage	Gui162	
A31	Hogs Back	Puttenham	N/A	N/A	Drainage	N/A	<b>Potential works following of last years maintenance</b>

Page 109

ITEM 13

3. This is a list of works being considered for future years
4. This list will change as condition survey information is received
5. This list is not in priority order

1. This is a list of works being considered for future years
2. This list will change as condition survey information is received

ITEM 13

Horizon 2 DRAINAGE Schemes for consideration for future years - continued							
Road No.	Road / scheme name	Location	Limits	Length (metres)	Type of Work	Surrey Highways ID	Other information
D76	Wharf Road	Ash Vale	N/A	N/A	Drainage	Gui161	<b>Minor curbing and drainage defect repairs.</b>

Page 110

Horizon 2 EMBANKMENT Schemes for consideration for future years							
Road No.	Road / scheme name	Location	Limits	Length (metres)	Type of Work	Surrey Highways ID	Other information
D203	Trunley Heath Road	Shalford	195 meters from junction with Horsham Road - Construction	N/A	Embankment		

3. This is a list of works being considered for future years
4. This list will change as condition survey information is received
5. This list is not in priority order

1. This is a list of works being considered for future years
2. This list will change as condition survey information is received

### Horizon 2 SAFETY BARREIRS Schemes for consideration for future years

Road No.	Road / scheme name	Location	Limits	Length (metres)	Type of Work	Surrey Highways ID	Other information
D46	Clay Lane	Burpham	C14-009 Barrier Site - Road Restraint System Works	N/A	Safety Barrier	C14-009	
A3100	Hogs Back	Puttenham	A31-101 Barrier Site - Road Restraint System Works	N/A	Safety Barrier	A31-101	

Page 111

### Horizon 2 TRAFFIC SIGNALS Schemes for consideration for future years

Road No.	Road / scheme name	Location	Limits	Length (metres)	Type of Work	Surrey Highways ID	Other information
A323	Aldershot Road	Guildford	Near Southway	N/A	Traffic signal refurbishment	P749	
A25	Epsom Road	Merrow	Near Merrow Street	N/A	Traffic signal refurbishment	P726	

ITEM 13

3. This is a list of works being considered for future years
4. This list will change as condition survey information is received
5. This list is not in priority order

1. This is a list of works being considered for future years
2. This list will change as condition survey information is received

Horizon 2 TRAFFIC SIGNALS Schemes for consideration for future years - continued

Road No.	Road / scheme name	Location	Limits	Length (metres)	Type of Work	Surrey Highways ID	Other information
A31	Farnham Road	Guildford	Junction with Bridge Street	N/A	Traffic signal refurbishment	J762	
A31	Farnham Road	Guildford	Near to Denzil Road	N/A	Traffic signal refurbishment	P718	
D898	High Street	Guildford	High Street And Millbrook	N/A	Traffic signal refurbishment	P799	
A25	Ladymead	Guildford	Junction with Woodbridge Road	N/A	Traffic signal refurbishment	J715	
A3100	Lower Eashing Road	Eashing	Near The Drive (Eashing Bridge River Way)	N/A	Traffic signal refurbishment	J790	

3. This is a list of works being considered for future years
4. This list will change as condition survey information is received
5. This list is not in priority order



1. This is a list of works being considered for future years
2. This list will change as condition survey information is received

Horizon 2 TRAFFIC SIGNALS Schemes for consideration for future years - continued

Road No.	Road No.	Road No.	Road No.	Road No.	Road No.	Road No.	Road No.
C15	Onslow Street	Guildford	Junction with Bridge Street	N/A	Traffic Signals	J738	
B3000	Quarry Street	Guildford	Junction with Millbrook	N/A	Traffic Signals	J728	
D207	Stoke Road	Guildford	Junction with Nightingale Road	N/A	Traffic Signals	J786	
D4023	Stoughton Road	Guildford	Near Badger Close (Railway Bridge)	N/A	Traffic Signals	J785	
A281	The Street	Tongham	Near Poyle Road	N/A	Traffic Signals	P704	

Page 119

3. This is a list of works being considered for future years
4. This list will change as condition survey information is received
5. This list is not in priority order

1. This is a list of works being considered for future years
2. This list will change as condition survey information is received

Horizon 2 TRAFFIC SIGNALS Schemes for consideration for future years - continued

Road No.	Road / scheme name	Location	Limits	Length (metres)	Type of Work	Surrey Highways ID	Other information
C119	The Street	Shalford	Near Dagley Lane	N/A	Traffic Signals	P734	
D4025	Woking Road	Guildford	Near Hazel Avenue	N/A	Traffic Signals	P781	
A320 / D4027	Woking Road	Guildford	Junction with A3 Off-Slip Road	N/A	Traffic Signals	J739	
A320	Woodbridge Road	Guildford	Junction with Commercial Road	N/A	Traffic Signals	J776	
C93	Woodbridge Road	Guildford	Near Lease Road	N/A	Traffic Signals	P741	

3. This is a list of works being considered for future years
4. This list will change as condition survey information is received
5. This list is not in priority order

1. This is a list of works being considered for future years
2. This list will change as condition survey information is received

**Horizon 2 MAJOR SCHEMES / SUSTAINABLE TRANSPORT PACKAGE / RESILIENCE Schemes for consideration for future years**

Road No.	Road / scheme name	Location	Limits	Length (metres)	Type of Work	Surrey Highways ID	Other information
N/A	HIF Slyfield	Guildford	N/A	N/A	HIF (Housing Infrastructure Fund)		<b>Scheme currently in very early stages of planning. Also awaiting further information from central government regarding funding.</b>  <b>The aim of this scheme is to making land usable for development and to alleviate congestion in the area.</b>
A31	Farnham Road Bridge	Guildford	N/A	N/A	Major Schemes	N/A	<b>Scheme currently in very early stages of planning.</b>
A31	Blackwater Valley Hot Spots	Guildford	N/A	N/A	Major Schemes	N/A	<b>Scheme currently in very early stages of planning.</b>
N/A	Guildford – Quality Bus Corridor	Guildford	N/A	N/A	Major Schemes	N/A	<b>Scheme currently in very early stages of planning.</b>
N/A	Guildford Flood Resilience	Guildford	N/A	N/A	Network Resilience	N/A	<b>Scheme currently in very early stages of planning.</b>

Page 15

ITEM 13

3. This is a list of works being considered for future years
4. This list will change as condition survey information is received
5. This list is not in priority order

1. This is a list of works being considered for future years
2. This list will change as condition survey information is received

ITEM 13

**Horizon 2 MAJOR SCHEMES / SUSTAINABLE TRANSPORT PACKAGE / RESILIENCE Schemes for consideration for future years - continued**

Road No.	Road / scheme name	Location	Limits	Length (metres)	Type of Work	Surrey Highways ID	Other information
A31	Guildford A31 Flood Resilience	Guildford	N/A	N/A	Network Resilience	N/A	<b>Scheme currently in very early stages of planning.</b>

Page 116

Please note this is a provisional list. We cannot guarantee that any scheme on this list will be carried out.

3. This is a list of works being considered for future years
4. This list will change as condition survey information is received
5. This list is not in priority order

## Surrey County Council Local Committee (Guildford) Forward Programme 2017/18

Formal public	13 June 2018	7pm	Guildford Borough Council Chamber * **
Formal public	19 Sept 2018	7pm	Guildford Borough Council Chamber * **
Formal public	12 Dec 2018	7pm	Guildford Borough Council Chamber * **
Formal public	20 March 2019	7pm	Guildford Borough Council Chamber * **

Topic	Purpose	Contact Officers
<b>13 June 2018</b>		
Highways	Highways Update	Frank Apicella/John Hilder
	LOCAL COMMITTEE SUBSTITUTE MEMBERSHIP, TASK GROUP MEMBERSHIP AND NOMINATIONS TO PARTNERSHIP	Jo Long
Parking	Parking	Andy Harkin GBC
Parking	GBC Overview and Scrutiny task group – on street parking	James Dearling GBC
Transport	Walnut Tree Close (TBC)	Rob Curtis

Please note the Forward Programme may be subject to change.

Topic	Purpose	Contact Officers
Cycling	Guildford to Godalming Greenway (cycle route)	Becky Wilson
Questions/Petitions		
<b>19 September 2018</b>		
Community Safety	Community Safety Update report	
Highways	Highways Update	Frank Apicella/John Hilder
Questions/petitions		

\* Guildford Local Committee 'Plus' refers to the agreement undertaken in 2014 by both councils to extend joint working arrangements through this committee.

\*\* Meetings will be webcast.